

# Science Notebooks in Grades K–2

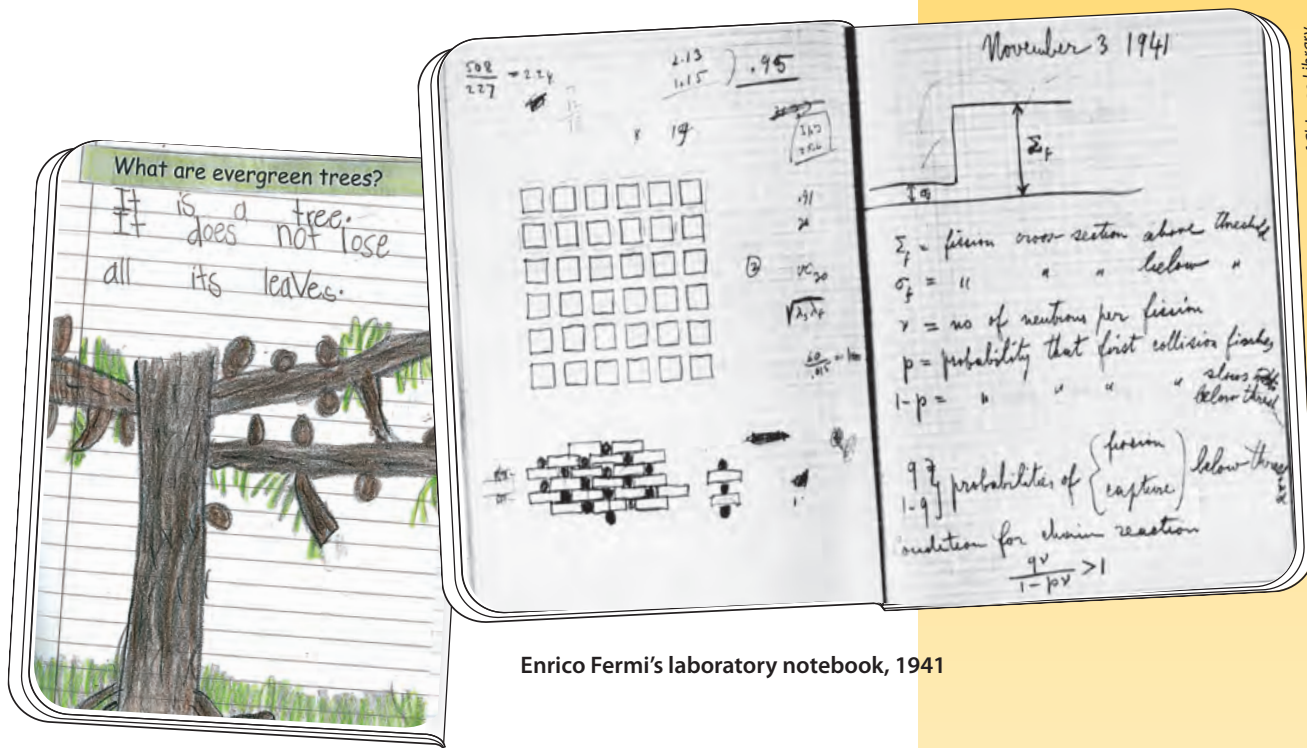

Student notebook from the Trees and Weather Module

Enrico Fermi's laboratory notebook, 1941

Source: Special Collections Research Center, University of Chicago Library

## INTRODUCTION

A scientist's notebook is a detailed record of his or her engagement with scientific phenomena. It is a personal representation of experiences, observations, and thinking—an integral part of the process of doing scientific work. A scientist's notebook is a continuously updated history of the development of scientific knowledge and reasoning. FOSS students are young scientists; they incorporate notebooks into their science learning.

This chapter is designed to be a resource for teachers who are incorporating notebooks into their classroom practice. For teachers just beginning to use notebooks, the Getting Started section in this chapter suggests how to set up the notebooks, and the *Investigations Guide* cues you when to engage students with the notebooks during the investigation. For more information on specific types of notebook entries, the subsections in the Notebook Components sections include strategies to differentiate instruction for various ability levels.

## Contents

Introduction .....	1
Notebook Benefits .....	2
Getting Started .....	7
Notebook Components .....	14
Planning the Investigation ....	14
Data Acquisition and Organization .....	15
Making Sense of Data .....	19
Next-Step Strategies .....	22
Writing Outdoors .....	25
Closing Thoughts .....	28



# Science Notebooks in Grades K–2

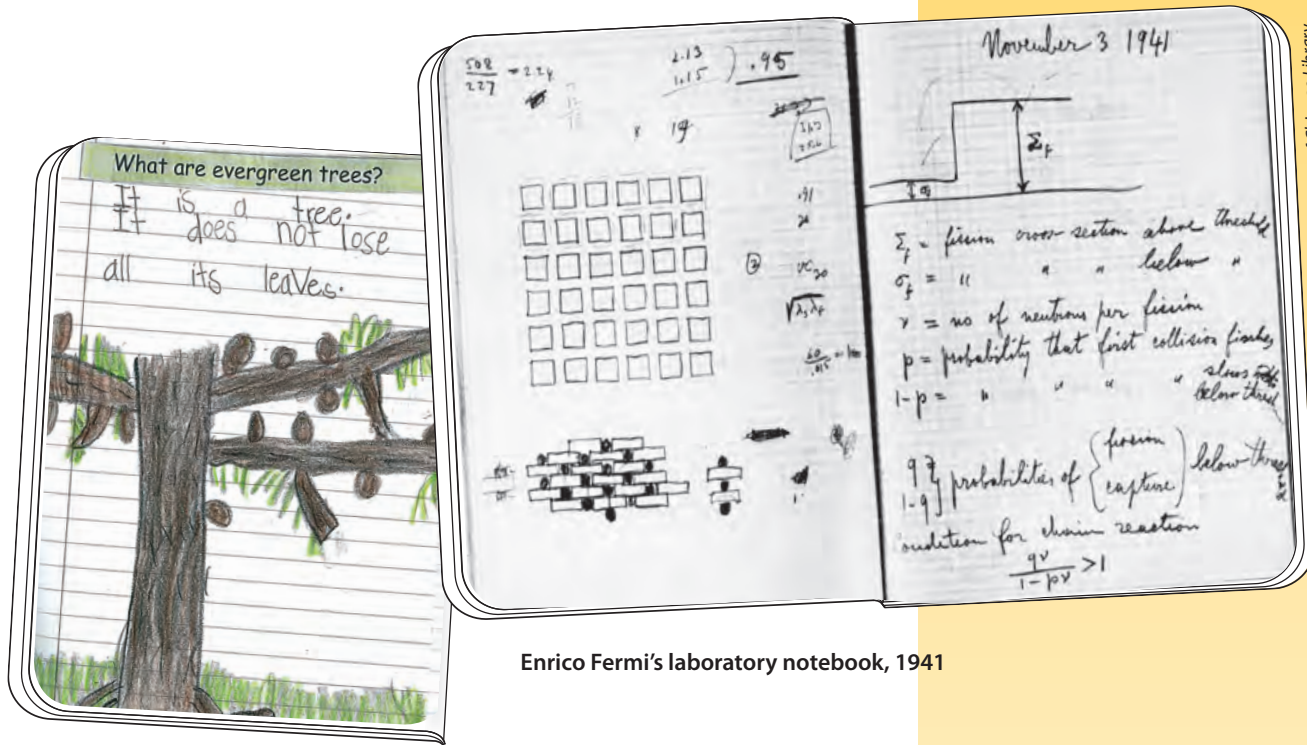

Student notebook from the Trees and Weather Module

Enrico Fermi's laboratory notebook, 1941

## INTRODUCTION

A scientist's notebook is a detailed record of his or her engagement with scientific phenomena. It is a personal representation of experiences, observations, and thinking—an integral part of the process of doing scientific work. A scientist's notebook is a continuously updated history of the development of scientific knowledge and reasoning. FOSS students are young scientists; they incorporate notebooks into their science learning.

This chapter is designed to be a resource for teachers who are incorporating notebooks into their classroom practice. For teachers just beginning to use notebooks, the Getting Started section in this chapter suggests how to set up the notebooks, and the *Investigations Guide* cues you when to engage students with the notebooks during the investigation. For more information on specific types of notebook entries, the subsections in the Notebook Components sections include strategies to differentiate instruction for various ability levels.

## Contents

Introduction .....	1
Notebook Benefits .....	2
Getting Started .....	7
Notebook Components .....	14
Planning the Investigation ....	14
Data Acquisition and Organization .....	15
Making Sense of Data .....	19
Next-Step Strategies .....	22
Writing Outdoors .....	25
Closing Thoughts .....	28





## Benefits to Students

- Documentation
- Reference document
- Cognitive engagement

## NOTEBOOK BENEFITS

Engaging in active science is one part experience and two parts making sense of the experience. Science notebooks help students with the sense-making part. Science notebooks assist with documentation and cognitive engagement. For teachers, notebooks are tools for gaining insight into students' thinking. Notebooks inform and refine instructional practice.

### Benefits to Students

**Documentation.** Science provides an authentic experience for students to develop their documentation skills. In the primary classroom, getting students to use a notebook will introduce the powerful skills of information organization. Students document their experiences, data, and thinking during each investigation. They create simple tables, graphs, charts, drawings, and labeled illustrations as standard means for representing and displaying data. At first, students will look at their science notebooks as little more than a random collection of words and pictures. Each notebook page represents an isolated activity. As students become more accomplished at keeping notebooks, their documentation will become better organized and efficient. In time and with some guidance, students will adopt a deeper understanding of their collections as integrated records of their learning.

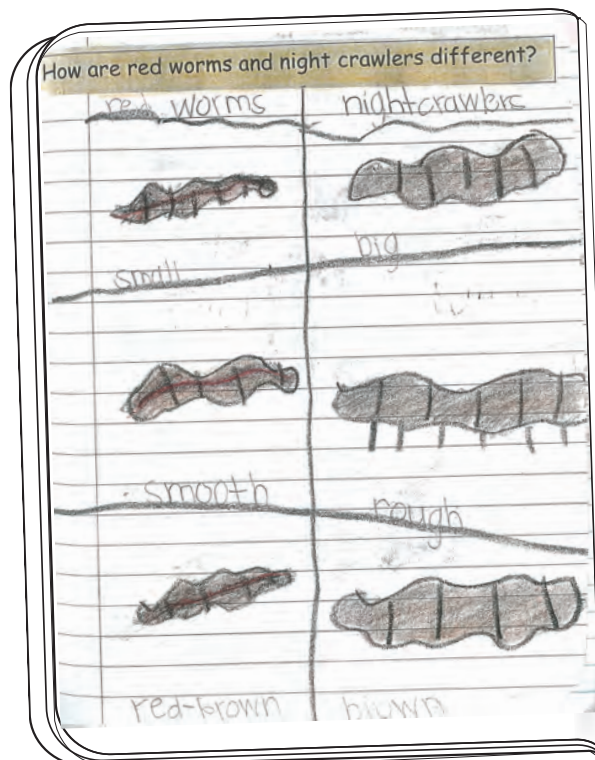

Kindergarten entry from the  
Animals Two by Two Module

**Reference document.** When data are displayed in functional ways, students can think about the data more effectively. Even with young students, a well-kept notebook is a useful reference document. When students have forgotten a fact about an insect or a plant that they learned earlier in their studies, they can look it up. Learning to trust a personal record of previous discoveries and knowledge structures is important.

A complete and accurate record allows students to reconstruct the sequence of learning events to “relive” the experience. Discussions about science among students; students and teachers; or students, teachers, and families have more meaning when they are supported by authentic documentation in students’ notebooks.

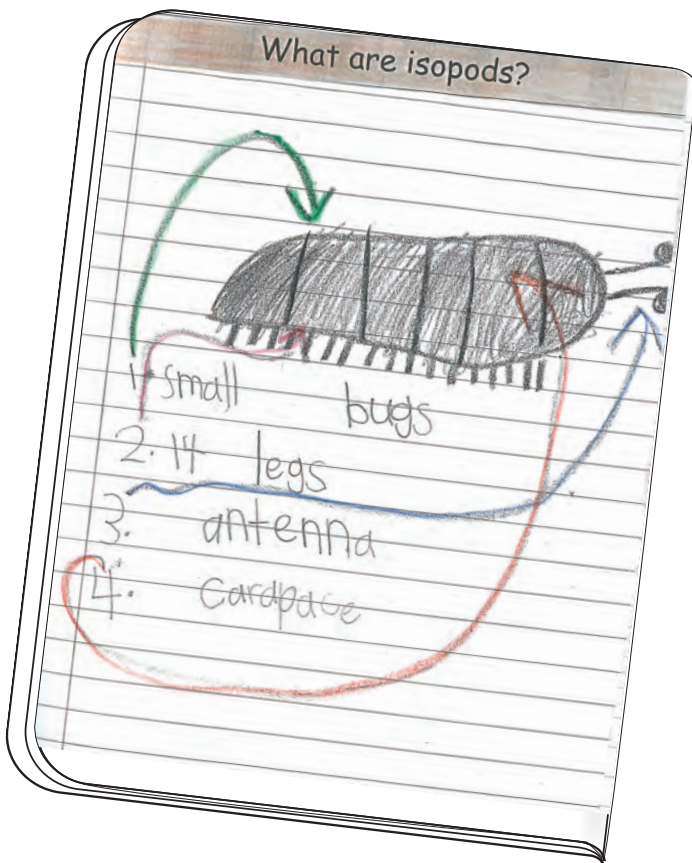

Labeled drawing from the Animals Two by Two Module

# Science Notebooks in Grades K–2

**Cognitive engagement.** Once data are recorded and organized in an efficient manner in science notebooks, students can think about the data to draw conclusions about the way the world works. Their data, based on their experiences and observations, are the raw materials that students use to forge concepts and relationships.

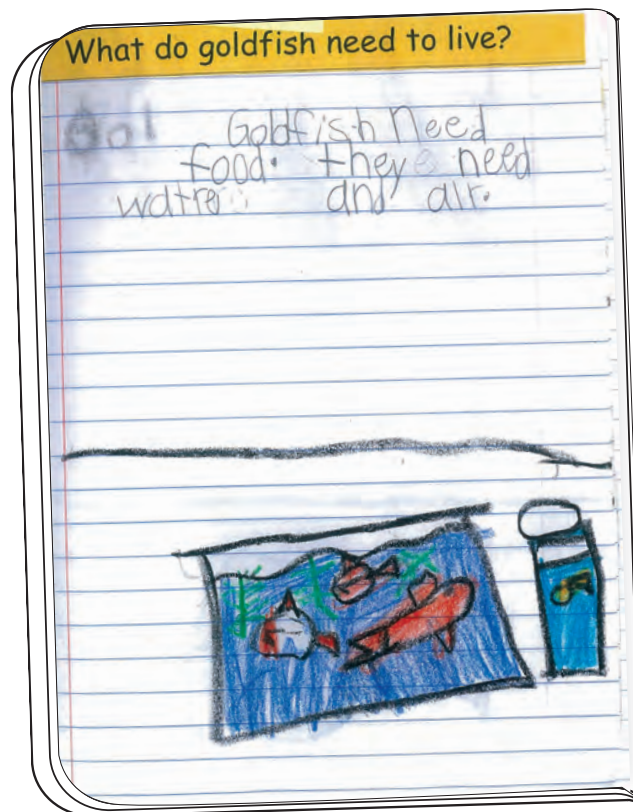

Responding to a focus question from the Animals Two by Two Module with a drawing and words

## Benefits to Teachers

In FOSS, the unit of instruction is the module—a sequence of conceptually related learning experiences that leads to a set of learning outcomes. A science notebook helps you think about and communicate the conceptual structure of the module you are teaching.

**Assessment.** From the assessment point of view, a science notebook is a collection of student-generated artifacts that exhibit learning. You can assess student skills, such as using drawings to record data, while students are working with materials. At other times, you collect the notebooks and review them in greater detail. The displays of data and analytical work, such as responses to focus questions, provide a measure of the quality and quantity of student learning. The notebook itself should not be graded. However, the notebook can be considered as one component of a student’s overall performance in science.

**Medium for feedback.** The science notebook is an excellent medium for providing feedback to individual students regarding their work. Some students may be able to read a teacher comment written on a self-stick note, think about the issue, and respond. Other students may need oral feedback individually or in a small-group situation. This feedback might include additional modeling to help students make more accurate drawings, revisiting some important vocabulary, or introducing strategies to help students better communicate their thinking.

**Focus for professional discussions.** The science notebook acts as a focal point for discussion about students’ learning at several levels. It can be reviewed and discussed during parent conferences. Science notebooks can be the focus of three-way discussions among students, teachers, and principals to ensure that all members of the school science community agree about what kinds of student work are valued and what level of performance to expect. Science notebooks shared among teachers in a study group or other professional-development environment can serve as a reflective tool that informs teachers of students’ ability to demonstrate recording techniques, individual styles, various levels of good-quality work, and so on. Just as students can learn notebook strategies from one another, teachers can learn notebook skills from one another.

## Benefits to Teachers

- *Assessment*
- *Medium for feedback*
- *Focus for professional discussions*
- *Refinement of practice*



A teacher provides feedback to a student.

# Science Notebooks in Grades K–2

**Refinement of practice.** As teachers, we are constantly looking for ways to improve instructional practices to increase students' understanding. Your use of the notebook should change over time. In the beginning, the focus will be on the notebook itself—what it looks like, what goes in it. As you become more comfortable with the notebook, the attention shifts to what students are learning. When this happens, you begin to consider how much scaffolding to provide to different students, how to use evidence of learning to differentiate instruction, and how to modify instruction to refine students' understanding.

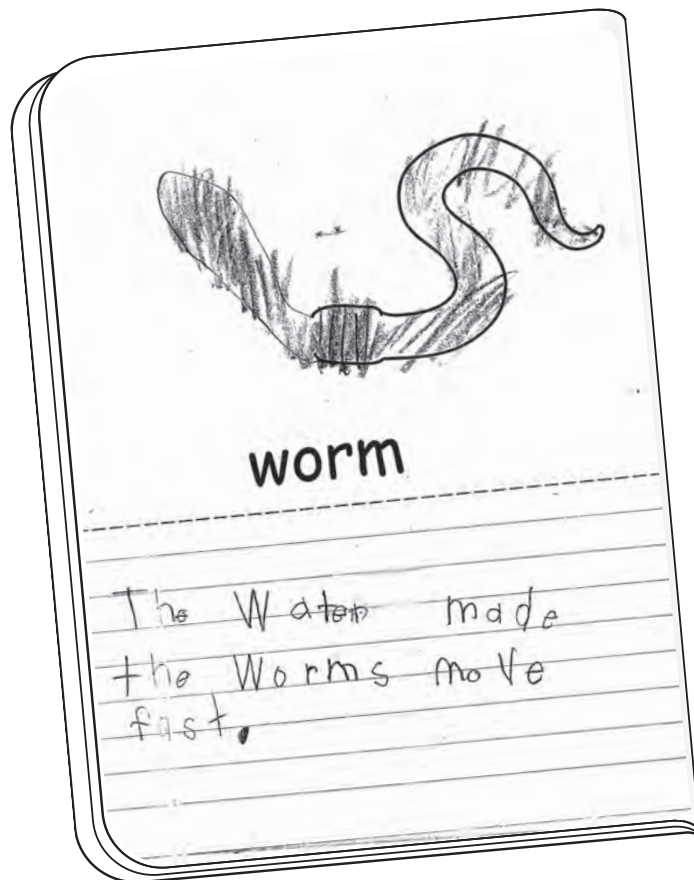

Kindergarten entry from the Animals Two by Two Module

## GETTING STARTED

Starting in kindergarten, students are expected to make detailed, thoughtful records of their science inquiries. While this may seem like a lofty goal, with some patience and thoughtful support, both teachers and students can learn how to use science notebooks effectively.

A major goal for using notebooks is to establish habits that will enable students to collect data and make sense of them. Use of the notebook must be flexible enough to allow students room to grow and supportive enough for students to be successful from the start. The format should be simple and the information meaningful to students. The notebook includes student drawings, simple writing in the form of individual words and short phrases, and a variety of visual and tactile artifacts. When students thumb through their notebooks, they are reminded of the objects and organisms they observed and their interactions with them.

### Notebook Format

Delta Education sells bound science notebooks that include printed notebook sheets specific for each module. These consumable, preprinted notebooks provide an efficient, supportive approach to early-childhood notebook keeping.

The *Teacher Resources* component of the FOSS *Teacher Toolkit* includes duplication masters for the same notebook sheets that are bound into the consumable notebooks. You can use these sheets to prepare an analogous notebook or to design a customized version.

In an autonomous approach, students create their entire science notebooks from blank pages in bound composition books. Students can glue or tape the provided notebook sheets into their notebooks, as well as create their own notebook entries. This level of notebook use will not be realized quickly and will require modeling by the teacher to provide enough structure to make the notebook useful. It will likely require systematic development by an entire teaching staff over several years.

You might choose to have a separate notebook for each module or one notebook for the entire year. (See the sidebar for the advantages of each.) Students will need about 30 pages (60 sides) for a typical module.

#### Advantages of One Notebook per Module:

- *Easy to replace if lost*
- *Lower cost*
- *Fewer pages*

#### Advantages of One Notebook per Year:

- *Easy to refer to prior activities*
- *Easy to see growth over time*



## Organization of Notebooks

Two organizational components of the notebook should be planned right from the outset for primary students—page numbering and documentation. Two additional organizational components—a table of contents and an index—might be included only in the class notebook (detailed in the Supporting Students section) or in student notebooks toward the end of second grade. Not all organizational structures need to be present in individual student notebooks in the primary grades.

**Page numbering.** Each page should have a number. These can be applied to the pages, front to back, and referenced in the table of contents as the notebook progresses, or small blocks of pages can be prenumbered (pages 1–5 initially, pages 6–10 later, and so on) at appropriate times in the module.

A parent volunteer could number the pages. If students number them, monitor their work to make sure they don't skip pages or misnumber them.

**Date, title, and other conditions.** Each time students make a new entry, they should record certain information. At the very minimum, they should record the date and a title. More complete documentation might include the time; day of the week; team members; and if appropriate, weather conditions. When introducing a new condition to students, such as recording the names of team members, it is important to discuss why students are recording the information so that they understand the relevancy.

Some classes start each new entry at the top of the next available page. Others simply leave a modest space and enter the information right before the new entry.

**Table of contents.** If students keep a table of contents in their own notebooks, they should reserve the first two pages of the notebook for it. You will need to remind students to add to it systematically as you proceed through the module. The table of contents can be based on the names of the investigations in the module, the specific activities undertaken, the concepts learned, or some other schema that makes sense to everyone.

You might provide students with a preprinted table of contents without page numbers. As students work through each investigation, they record the relevant page numbers in their table of contents. If students are making their own table of contents, they should keep it fairly simple.

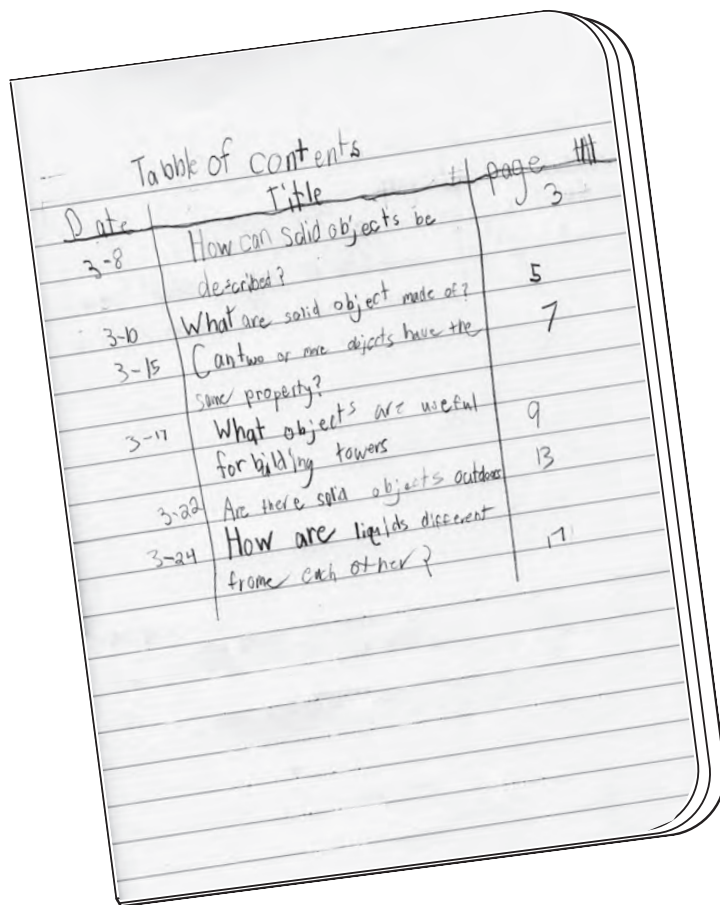

Table of contents		
Date	Title	Page #
3-8	How can solid objects be described?	3
3-10	What are solid objects made of?	5
3-15	Can two or more objects have the same property?	7
3-17	What objects are useful for building towers?	9
3-22	Are there solid objects outdoors?	13
3-24	How are liquids different from each other?	17

A table of contents for the Solids and Liquids Module

# Science Notebooks in Grades K–2

**Index.** Scientific academic language is important. FOSS strives to have students use precise, accurate vocabulary at all times in their writing and conversations. Key words can be displayed using a pocket chart, word wall, or written on index cards kept in boxes at each table. Another support to assist with acquisition of the scientific vocabulary is to introduce an index in the class notebook. It is not usually possible to enter the words in alphabetical order, since they will be acquired as the module advances. Instead, assign a block of letters to each of several index pages at the back of the class notebook (A–E, F–K, etc.); you or students can enter key words. Students write the new vocabulary word or phrase in the appropriate square and tag it with the number of the page on which the word is defined in the notebook.

Including an index in the class notebook is a long-term time investment and can be overwhelming for the beginning notebook user. It may be better to forgo the index and use just a word wall to work with vocabulary initially.



Pocket charts can be used to introduce vocabulary for students to include in their notebooks.

## Notebook Entries

As students engage in scientific exploration, they will make entries in their notebooks. They might use a prepared notebook sheet or a more free-form entry. Students frequently respond to a focus question with a drawing or a simple written entry. Kindergartners may write single words; first and second graders will write simple observations and summary ideas, using the new vocabulary in their entries. These notebook entries allow early-childhood students to relive and describe their science experiences as they turn the pages in their notebooks.

Typically, the rules of grammar and spelling are relaxed when making notebook entries so as not to inhibit the flow of creative expression. Encourage students to use many means of recording and communicating besides writing, including charts, graphs, drawings, color codes, numbers, and images attached to the notebook pages. By exploring many options for making notebook entries, each student will find his or her most efficient, expressive way to capture and organize information for later retrieval.

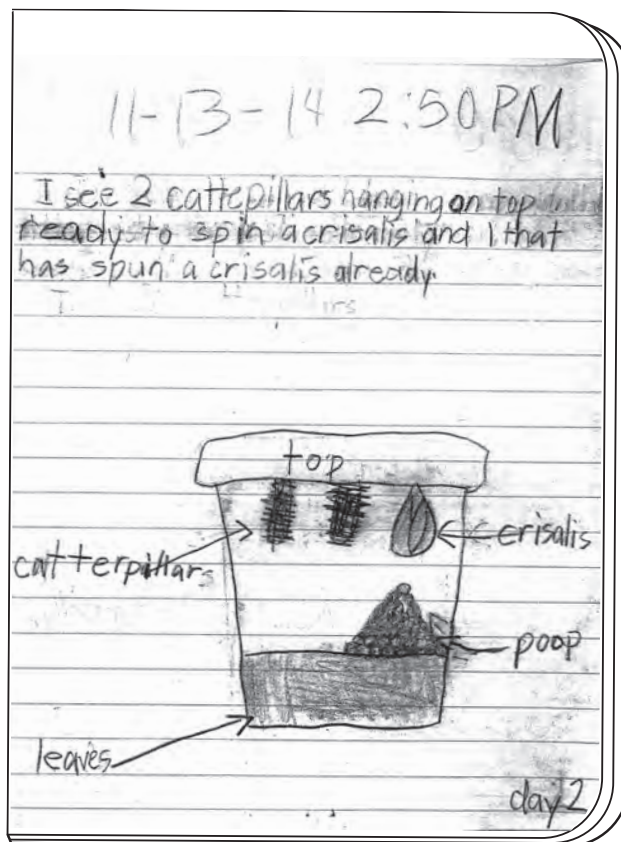

A notebook entry from the Insects and Plants Module

## TEACHING NOTE

*Use of the class notebook should be thoughtfully timed. Doing a class-notebook entry at the end of an activity is helpful to teach the components of a notebook, yet allows you to see what students do on their own. If you want to model a specific notebook strategy, use the class notebook during the activity.*

## Supporting Students

Elementary classrooms contain students with a range of abilities, which is important to take into account when thinking about strategies for implementing science notebooks. Students need to have successful early experiences with notebooks. This requires planning. For younger students, a blank notebook may be intimidating, and they will look to you for guidance. FOSS teachers have had success using different supports and scaffolds to help transform the blank notebook into a valuable reference tool.

**Class notebook.** You can create a class notebook to document scientific explorations as a way to model the various notebook components. Use a chart-paper tablet so that the pages can be flipped back and forth, and make it accessible at all times as a student reference. Students can emulate the class notebook in their own personal notebooks. Initially, individual notebooks will look quite similar to the class notebook. It is not the intent that students' notebooks be identical to the class notebook.

**Scaffolds.** Supports and scaffolds differ in one way. Supports are always available for students to access, such as allowing students access to a class notebook. Scaffolds are available just when the student needs them and will vary from student to student and from investigation to investigation. Scaffolds are meant to provide structure to a notebook entry and allow students to insert their observations into that structure. As the year progresses, the scaffolds change to allow for more student initiative. Scaffolds include

- **Sentence starters** or **drawing starters** provide a beginning point for a notebook entry.
- **Frames** provide more support but leave specific gaps for students to complete. Here's an example: "We planted \_\_\_\_\_ seeds and used \_\_\_\_\_ to water them."
- The suggested **notebook sheets** can guide students to record observations and data. The notebook sheets also guide thinking.

**Think-alouds.** Think-alouds help explain the decision-making process practiced by a savvy notebook user. They verbalize the thoughts used to create a particular notebook entry. For example, if students have recorded observations about one type of rock and are going to observe a second type, you might say,

*I am going to observe another kind of rock. I'm going to look back to see how I recorded rock information before. I see that I made a large, detailed drawing. I described the texture, size, and color of the rock, too. So now I think I will make a drawing of the new rock. I'm going to record the texture, size, and color, too.*

*Now I know that one way I can get ideas for what to write in my notebook is to look back at observations I wrote before.*

**Providing time to record.** When young students are engaged in active science, their efforts are focused on the materials, not the notebook. Students need this time to explore, and many will not open their notebooks and record observations, even with prompting. Students need separate time to record observations that fully document their discoveries. Some teachers have found it easier to leave the materials on the table and have students bring their notebooks to a common writing area. Then the teacher revisits the focus question or task and provides a few minutes for students to record in their notebooks.

**Dictation.** Students could dictate specific information to an adult. The adult writes the information in the notebook for the student. Or the adult could write the sentence, using a highlighter, and students could trace the words, using a pencil.

## Ownership

A student's science notebook can be personal or public. If the notebook is personal, the student decides how accessible his or her work is to other students. If ownership falls at the opposite extreme, everything is public, and anyone can look at the contents of anyone else's notebook at any time. In practice, most classroom cultures establish a middle ground in which a student's notebook is substantially personal, but the teacher claims free access to the student's work and can request that students share notebooks with one another and with the whole class from time to time.

# Science Notebooks in Grades K–2

## Notebook Components

- *Planning the investigation*
- *Data acquisition and organization*
- *Making sense of data*
- *Next-step strategies*

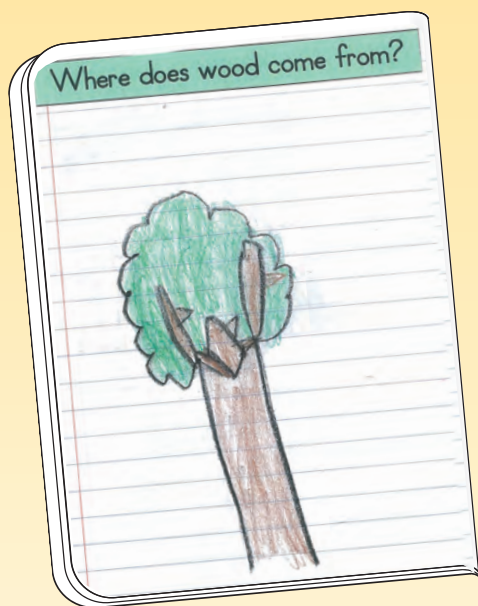

Notebook entry with focus question from the Materials in Our World Module

## TEACHING NOTE

*Student-developed plans appear infrequently in grades K–2. Asking students to record plans for every investigation is not recommended.*

## NOTEBOOK COMPONENTS

A few components give the science notebook conceptual shape and direction. These components don't prescribe a step-by-step procedure for how to prepare the notebook, but they do provide some overall guidance.

The general arc of an investigation starts with a question or challenge, and then proceeds with an activity, data acquisition, sense making, and next steps. The science notebook should record important observations and thoughts along the way. It may be useful to keep these four components in mind as you systematically guide students through their notebook entries.

### Planning the Investigation

Typically at the start of a new activity, the first notebook entry is a focus question, which students glue or transcribe into their notebooks. The focus question determines the kinds of data to be collected and the procedures that will yield those data. Depending on the timing and their previous experiences, students may be asked to record a prediction related to the focus question.

**Focus question.** Each part of each investigation starts with a focus question or challenge. The focus question establishes the direction and conceptual challenge for the activity. Write or project it on the board or on the chart for students to transcribe into their notebooks, or give them photocopied strips of the focus question to tape or glue into their notebooks. The focus-question strips are distributed as needed. Some teachers give students adhesive-backed labels with the focus questions printed on them.

### 3. How can you sink wood?

Write the focus question on the chart, and have students read it together.

➤ *How can you sink wood?*

**Plans and procedures.** Students may plan their investigation. The planning may be detailed or informal, depending on the requirement of the investigation. These plans take time to develop and additional time to document in the notebook. A brief class discussion of the procedure may lead to a sentence or two recorded in the class notebook. This will be sufficient for many of the investigations.

**Predictions.** Depending on the content and the focus question, students may be able to make a prediction. When they make predictions, they are attempting to relate prior experiences to the question posed. Providing students with a frame can help them explain the rationale behind their predictions. A frame to help with stating a prediction is “I think that \_\_\_\_\_ because \_\_\_\_\_.”

## Data Acquisition and Organization

Data are the bits of information (observations) from which scientists construct ideas about the structure and behaviors of the natural world. Because observation is the starting point for answering the focus question, data records should be

- clearly related to the focus question;
- accurate and precise;
- organized for efficient reference.

Data handling can have two phases: data acquisition and data display. Data acquisition is making observations and recording data. The data record can be composed of words, phrases, numbers, and/or drawings. Data display is reorganizing the data in a logical way to facilitate thinking. The display can take the form of narratives, drawings, artifacts, tables, graphs, images, or other graphic organizers. Early in a student’s experience with notebooks, the record may be disorganized and incomplete, and the display will need guidance. Students will need support to determine what form of recording to use in various situations and how best to display the data for analysis.

**Narratives.** The most intuitive approach to recording data for most students is narrative—using words, sentence fragments, and numbers in a more or less sequential manner. As students make a new observation, they record it right after the previous entry, followed by the next observation, and so on. Some observations, such as the changes observed in a mealworm, are appropriately recorded in narrative form.

Sentence frames provide a way for students to record their data. If students are nonwriters, they can dictate their observations, and you can write their observations in their notebooks, using a highlighter. Students can then trace the highlighted words.

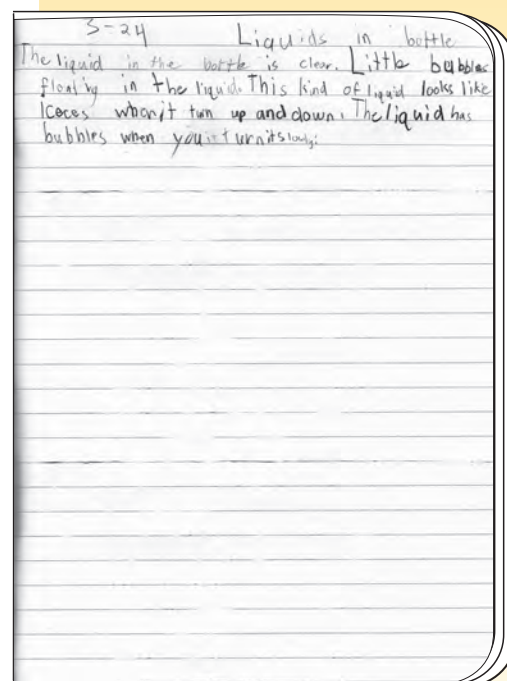

A narrative observation from the Solids and Liquids Module



# Science Notebooks in Grades K–2

**Drawings.** When students observe organisms or systems, a labeled illustration is a very efficient way to record data. A picture is worth a thousand words, and a labeled picture is even more useful.

Some young students may initially prefer drawing their observations, while others may struggle to do so. When students make drawings, it can be helpful to suggest an acronym for making useful drawings. Accurate, big, colorful, and detailed (ABCD) drawings can capture structures of an organism, a balanced object, or an observation of a liquid. Think-alouds can also help students gain insight about not only what to draw but also when a drawing is useful.

It is not unusual for students to embellish their drawings by adding features such as smiles to flowers and living organisms. While this may be appropriate for creative expression, scientific illustrations should not be anthropomorphized. Give students feedback about making authentic observations.

**Artifacts.** Occasionally, the results of an investigation produce three-dimensional products that students can tape or glue directly into their science notebooks. Rubbings, disassembled fabrics, sand, minerals, seeds, and so on can become a permanent part of the record of learning.

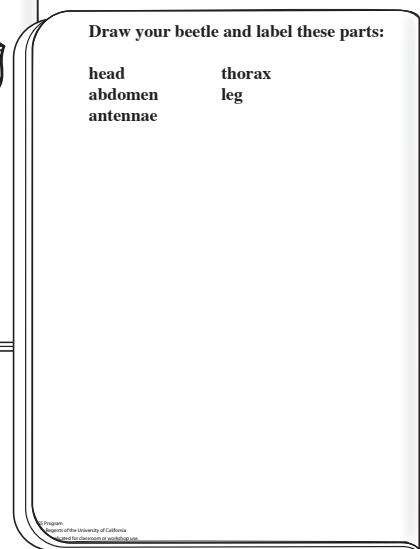
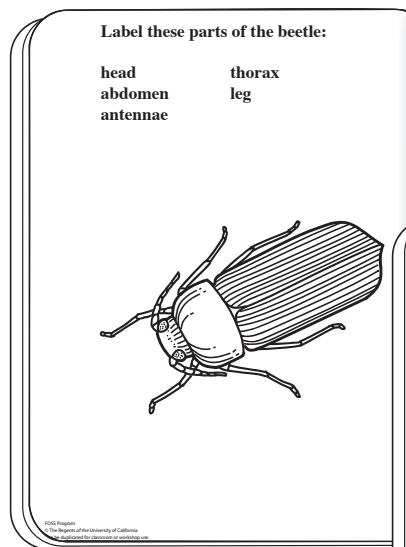
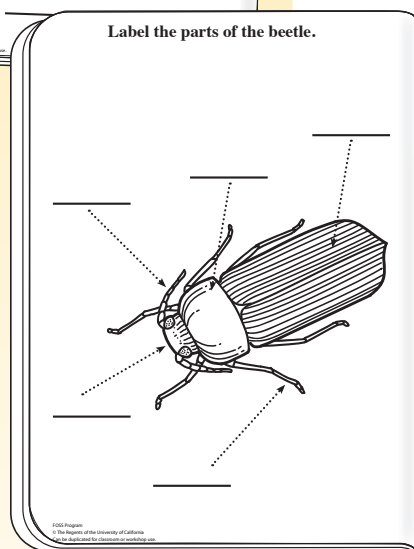
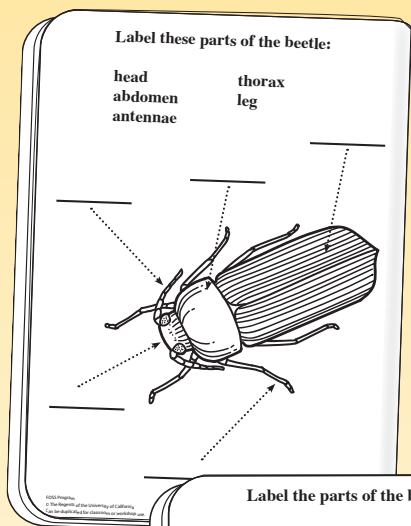

An example of different drawing scaffolds for the parts of a beetle. Different scaffolds can provide different levels of support for students. It is important to note that not all students need the same level of support.

**Tables.** When students make similar observations about a series of objects, such as properties of solid objects, a table with columns is an efficient recording method. The two-dimensional table makes it easy to compare the properties of all the objects under investigation.

Often, the preprinted notebook sheet provides a blank table. Students can quickly enter information on the notebook sheet. As students take on more independence in their notebooks, discussions about the column headings or the purpose of the tables shift the focus from filling in the table to the purpose the table serves.

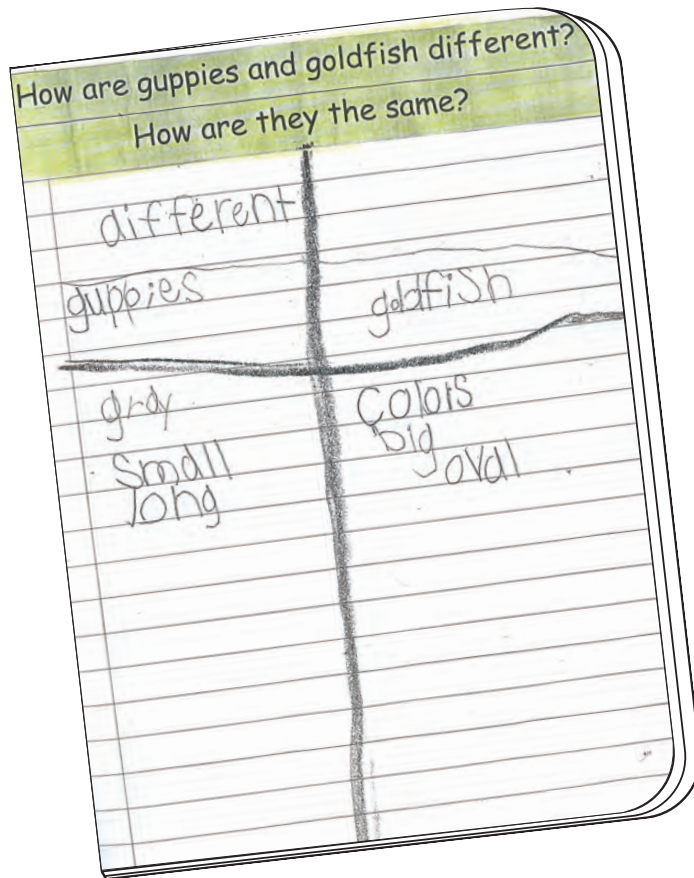

How are guppies and goldfish different?	
How are they the same?	
guppies	goldfish
gray	Colors
small	big
long	oval

A simple table from the Animals Two by Two Module

**Graphs and graphics.** Reorganizing data into a logical, easy-to-use graphic is an important phase of data analysis. Bar graphs allow easy comparison. Additional graphic tools, such as concept maps and life cycles, help students make connections between data accrued during investigations.

For kindergarten students, you will need to model and scaffold graphs and graphics when students are ready. Visuals displayed in students' notebooks should also appear in a larger format on a whiteboard, projected display, or in the class notebook. You can use this larger display to connect organized data to the content students are learning.

**Images.** Digital photos of plants, rocks, and the results of investigations can be great additions to the science notebook.

## Making Sense of Data

The third component of an investigation involves analyzing the data to learn something about the natural world. Establishing the habit of thinking about the data collected and using them to help us answer a question is important.

Most of the sense making in the primary classroom takes place during whole-group discussions when students share and discuss the observations they made while investigating. Questions are asked to help students interpret and analyze data in order to build conceptual understanding. Encourage students to use new vocabulary when they are sharing and making sense of their data. These words should be accessible to all students in the class notebook and displayed in the room. When students have limited written language skills, this oral discussion is important. This sharing is essential and is described in detail in the *Investigations Guide*. After sharing observations, the class revisits the focus question. Students flip back in their notebooks and use their data to discuss their answers to the question. You scaffold the discussion, and use appropriate language-development strategies.

### 8. Ask questions to guide discussion

Ask questions to guide students' observations and discussion.

- ▶ *Were you able to sink the wood by attaching paper clips?*
- ▶ *How many paper clips did you use to sink the wood?*
- ▶ *Let's compare the two samples. Does it take the same number of paper clips to sink both kinds of wood?*
- ▶ *Does it make a difference where you put the paper clips on the wood? All on one side? Evenly distributed around all sides?*

After the sense-making discussion, students might review relevant vocabulary. Then they answer the focus question in their notebooks. In the beginning, you might model this writing in a class notebook, or students might work in small groups to write a collaborative response. Students could also make a drawing as a response to a focus question. As students become more proficient writers, they will begin to record their own written responses to the focus question.

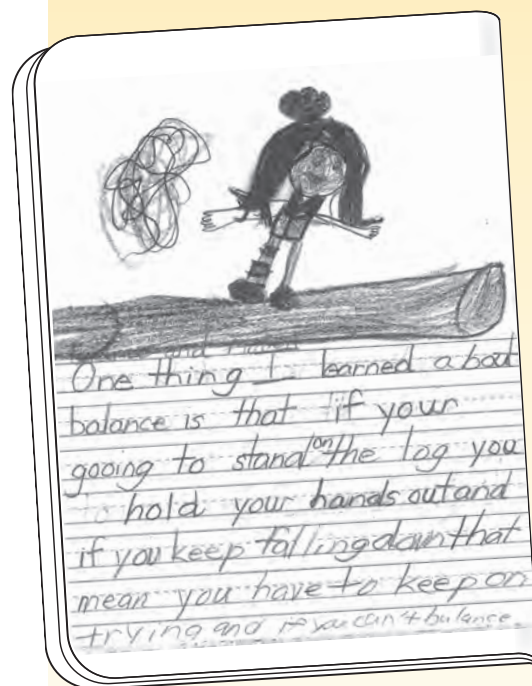

A sense-making entry from the Balance and Motion Module

# Science Notebooks in Grades K–2

Making sense of data is an opportunity for students to grapple with scientific concepts. The expectation is that all students will engage in this component. In many instances, using assistive structures, such as frames and prompts to guide the development of a coherent and complete response to the focus question, will help establish this expectation.

**Thinking with evidence.** In the primary classroom, students are expected to explain their thinking and provide some supporting evidence. While their explanations and evidence may be relatively simple, they will provide you with evidence of student understanding. A student might conclude that objects that have a round surface will roll because a ball and a can both rolled and they have round surfaces. The evidence should refer to specific observations, measurements, and so on.

For example, an investigation in the **Animals Two by Two Module** poses the focus question

► *What is the difference between red worms and night crawlers?*

Students observe and record, using the class notebook as a model. You create a Venn diagram, with input from students during discussion that compares the two types of worms. Students hear the focus question again, and they discuss their thinking in their groups. You write this frame in the class notebook

*One difference between a red worm and a night crawler is \_\_\_\_\_ .  
I know this because \_\_\_\_\_ .*

All students get a preprinted frame to glue into their notebooks and answer independently. Be careful not to display conclusions or other sense-making entries in a class notebook before students make their own entries. Otherwise, assessment of student thinking becomes difficult, as a student may copy the class-notebook response with little understanding of the meaning.

## TEACHING NOTE

*If students respond verbally, it is important to record those responses in the science notebook to establish that notebooks are a place to document understandings.*

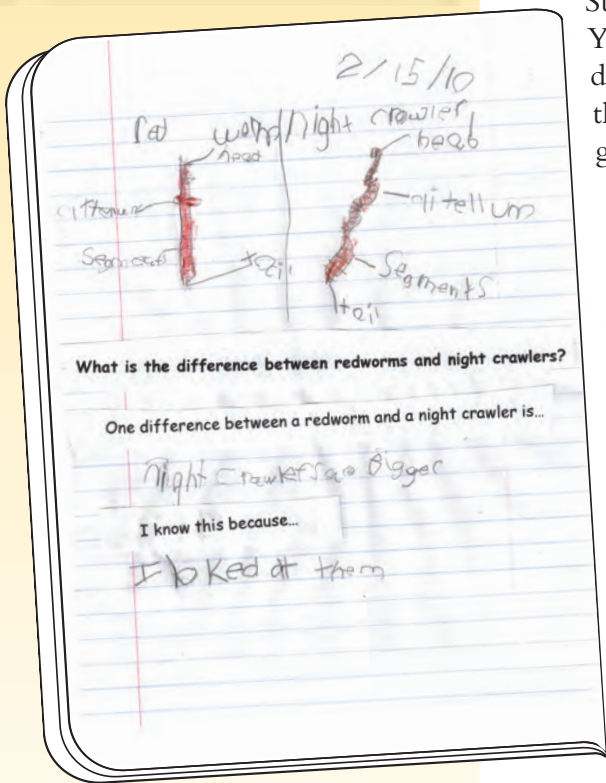

An answer to a focus question from the **Animals Two by Two Module**

**Frames and prompts.** Providing frames helps students organize their thinking. The frame provides a communication structure that allows students to focus on thinking about the science involved. This could be identifying the difference between two worms, students’ thoughts about which types of objects roll, or how people can change the shape of wood. The frame does not do the thinking for students, but allows them to respond to the focus question in a clear, coherent manner.

- *One difference between the red worm and the night crawler is \_\_\_\_\_.*
- *I noticed that all the things that rolled \_\_\_\_\_.*
- *I know this because \_\_\_\_\_.*

**I wonder.** Does the investigation connect to a student’s personal interests? Or does the outcome suggest a question or pique a student’s curiosity? Providing time for students to write “I wonder” statements or questions supports the idea that the pursuit of scientific knowledge does not end with the day’s investigation. The notebook is an excellent place to capture students’ musings and for students to record thoughts that might otherwise be lost.

**Wrap-up/warm-up.** At the end of each investigation part or at the beginning of the next part, students will engage in a wrap-up or warm-up. This is another opportunity for students to revisit the content of the investigation. As they discuss their responses to the focus question with a partner, students may choose to edit their responses or add fresh information. This should be encouraged.

### TEACHING NOTE



*Frames can be used to model how to write a good response. Some students may be able to revisit and modify previously used frames to answer additional questions.*

### 13. Share notebook entries

Conclude Part 4 or start Part 5 by having students share notebook entries. Ask students to open their science notebooks to the most recent entry. Read the focus question together as a class.

➤ *How can you sink wood?*

Ask students to pair up with a partner to

- share their answers to the focus question;
- explain their drawings.

# Science Notebooks in Grades K–2

## TEACHING NOTE

*Students' learning can be assessed only at the level in which it was done. If students worked in groups to answer the focus question, it is difficult to assess individual understanding. Similarly, providing a frame to guide a student response provides evidence on what students can do at a supported level, not at an independent level.*

## TEACHING NOTE

*These next-step strategies should be kept simple for primary students. The key idea is that students can revise their responses after gaining more information.*

## Next-Step Strategies

In each investigation, the *Investigations Guide* indicates an assessment opportunity and what to look for when examining students' work. The purpose of looking at students' work at this juncture is for formative, or embedded, assessment, *not* for grading. Look for patterns in students' understanding by collecting and sorting the notebooks. If the patterns indicate that students need additional help with communication or with content, you might want to select a next-step strategy before going on to the next part. This process of looking at students' work is described in more detail in the Assessment chapter.

A next-step strategy is an instructional tool designed to help students clarify their thinking and usually takes place before the start of the next investigation part. A strategy is selected based on students' needs. It may be that a student needs to communicate his or her thinking more efficiently or accurately or to use scientific vocabulary. A student may need to think about the concept in a different way. Because many young students are not able to articulate their thinking well in writing, it can be difficult to discern the area of need.

What follows is a collection of next-step strategies that teachers have used successfully with groups of students to address areas of need. These strategies are flexible enough to use in different groupings and can be modified to meet your students' needs.

**Teacher feedback.** Students' writing often exposes weaknesses in students' understanding—or so it appears. It is important to check whether the flaw results from poor understanding of the science or from imprecise communication. When students are able to read your comments, you can use self-stick notes to provide constructive feedback or dig deeper into students' thinking. The note might pose a question designed to move a student's thinking forward or to clarify an explanation. The student acts independently on the question.

When students have not developed the reading skills necessary to act independently on written feedback, read the question or prompt to the student. Language skills are supported when students have the opportunity to connect the written feedback to what you read to them.

The most effective forms of feedback relate to the content of the work. Here are a couple of examples.

- *Label your drawing to show the parts of the plant.*
- *Tell me why you think you were able to balance the triangle and the arch.*

Nonspecific feedback (such as stars, smiley faces, and “good job!”) and ambiguous critiques, (such as “try again,” “put more thought into this,” and “not enough,”) are less effective. Feedback that guides students to think about the content of their work and gives suggestions for how to improve are productive instructional strategies. Here are some examples of useful generic feedback.

- *Use the science words in your answer.*
- *Can you tell me why you think that?*
- *Why do you think that happened?*

Students return to their notebooks and read or listen to the feedback at the start of the next investigation. They can discuss this feedback with a partner during the warm-up time and refine their responses. You could model this refinement as a think-aloud or by using the class notebook. Monitor students to ensure that they are acting on the feedback provided.

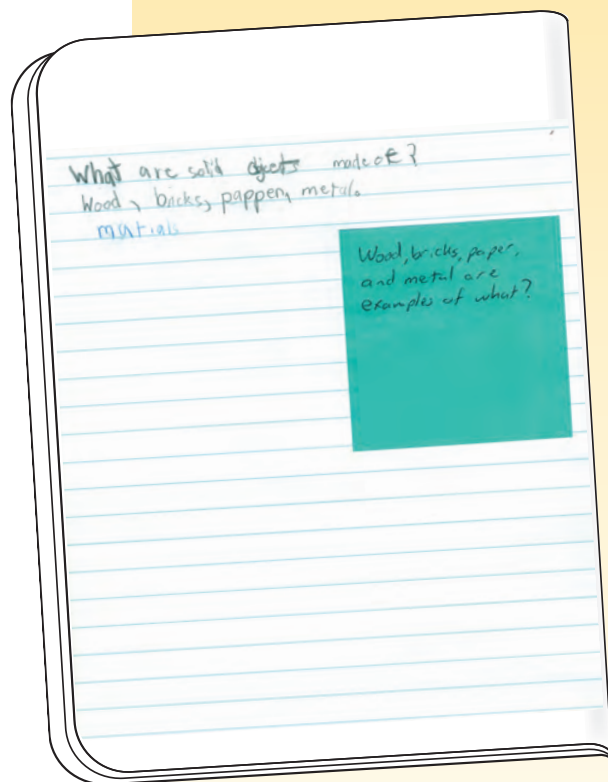

Students can respond to feedback by using a different color to show their new understanding.



# Science Notebooks in Grades K–2

**Review and critique anonymous student work.** Presenting work from other students can be a valuable learning tool for refining and improving the content and literacy of responses. Depending upon the culture of the class, you might present actual or simulated student work from a focus question or responses that reflect a common misconception, error, or exemplary work. Present it to the class in a common gathering area, such as on a rug, or display it electronically while students are at their seats. Present one simple response, such as a labeled drawing. Students then work in a group to discuss the merits and recommend improvements to the student response. In this process, students discuss what information is needed for a quality response. After critiquing other students' responses, students look at their own responses and refine their thinking. Students could also use a different-color crayon or pencil to make changes to their own responses.

**Key points.** Pose the focus question to the class, and, through discussion, elicit the key ideas or points that would completely answer the question. List only key words or brief phrases on the board. If you have already recorded the key points in the class notebook, revisit that

list as well. Once the class has agreed on the key points, students review their own responses, looking for the key points. You can guide this by calling out each key point on the list, and asking students to put a finger on it in their notebooks. If students need to add the key point, they can add it in another color.

**Mini-lessons.** Sometimes the data from sorting notebook entries reveal that students need some information repeated or specific guidance on a skill. A mini-lesson is a brief interaction with a group of students that addresses a specific area of need. You might have a group of students observe a mealworm more closely in order to count the number of segments, or give students a writing prompt and work with them to explain their thinking more clearly.



## WRITING OUTDOORS

Every time you go outdoors with students, you will have a slightly different experience. Naturally, the activity or task will be different, but other variables may change as well. The temperature, cloud cover, precipitation, moisture on the ground; other activities unexpectedly happening outside; students' comfort levels related to learning outdoors; and time of the school year are all aspects that could affect the activity and will certainly determine how you incorporate the use of notebooks. The following techniques are tried-and-true ways to help students learn how to write outdoors and to give them all the supplies they need to support their writing.

### Create “Desks”

Students need a firm writing surface. Students who write in composition notebooks with firm covers can simply fold them open to the pages they are writing on, rest them in the crook of their nonwriting arms, and hold them steady with their nonwriting hands—they can stand, sit, kneel, or lean against a wall to write. At the beginning of the school year, take a minute to model how to do this.

Many students feel most comfortable sitting down to write. Curbs, steps, wooden stumps or logs, rocks, and grass are places to sit while writing. Select a writing location that suits your students' comfort levels. Some students will not be comfortable sitting on the grass or ground at first. They will need to sit on something such as a curb, boulder, or wooden stump at the start of the year, but will eventually feel more comfortable with all aspects of the outdoor setting as the year moves along.

If students are using individual notebook sheets or notebooks with flimsy covers, you will likely want to buy or make clipboards. If you do not have clipboards, use a box cutter to cut cardboard to the proper size. Clamp a binder clip at the top to make a lightweight yet sturdy clipboard. If it gets ruined, no tears will be shed. If you're in the market for new clipboards, get the kind that are stackable and do not have a bulky clip. Ideally, all the clipboards will fit in one bag for portability and easy distribution.

If using a notebook sheet, simply put the sheet on the clipboard before going outdoors, and have students glue the sheet into their notebooks when you are back in the classroom. An elastic band around the bottom of the clipboard, or around a stiffer composition notebook, will help keep the paper from flapping around and becoming too weathered.

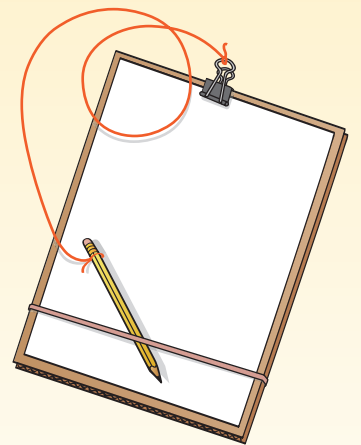

## Bring Writing Tools Outdoors

Almost always, students will set up their notebooks indoors so that they know what is expected of them outdoors. If students will be recording data, they will carry their pencils and notebooks or clipboards outdoors and hold on to them the entire time. Make sure students understand how and what to record.

You can bring chart paper outdoors. Roll up a blank piece of chart paper, grab some blue painter's tape, and stick the piece of paper to the school wall. You'll need to tape all four corners. Or set up a chart inside and clip it to a chain-link fence with binder clips or clothespins when you go outdoors.

Take along extra pencils, as many pencil points will break. Some teachers find it helpful to tie pencils onto clipboards. Pencils should be tucked between the clip and the notebook sheet so that students don't poke themselves or, more likely, accidentally break the pencil points.

Another option is to prepare a cloth bag containing small pencil sharpeners, extra pencils, and other science tools, such as vials, hand lenses, and rulers.

## Decide When to Write Outdoors

In general, notebook entries will be more detailed and more insightful if students can stay outdoors where the scientific exploration occurred. Sometimes, you will want to complete notebook entries indoors. If you are teaching the module early in the year when students are building up the routines for using the schoolyard, or if the weather is not ideal (a little chilly, raining, too hot, too windy), then you may want students to make notebook entries after returning to the classroom. If students are totally focused and in the moment, they can stay outdoors while they answer the focus question. If other students are outdoors playing, you may need to bring the class indoors to complete the written work. Only you will be able to determine what is best at the time.



## CLOSING THOUGHTS

Engaging primary students in active science with notebooks provides a rich experience. Doing this successfully requires thoughtful interactions among students, materials, and natural phenomena. Initially, adding notebooks to your science teaching will require you to focus students' attention on how to set up the notebook, what types of entries students should make, and when students should be using their notebooks. You will establish conventions about where to record the date and title, where to keep notebooks, how to glue notebook sheets into notebooks, and when to record observations and thinking.

Once you are past these perfunctory issues, you can shift your focus to the amount of scaffolding to provide to students or to encouraging students to create their own notebook entries. During this time, you and your students are developing skills to improve the quality of notebook entries. These skills may include asking better questions to focus students' attention on a specific part of an organism or using color to enhance a drawing. Students begin to make entries with less prompting. They give more thought to supporting their responses to the focus question. When asked to make a derivative product, students thumb through their notebooks to find the needed information. The notebook becomes a tool for students to help recall their learning.

As students begin to document their thinking about focus questions and other queries, you may begin to wonder, "Should I be doing something with their notebooks?" This is when your focus shifts from the notebook as just something students use during science learning to the notebook as an assessment tool. Once everyone is comfortable recording the focus question and collecting data, you can take the next step of collecting notebooks and reading students' responses as a measure of not just how individual students are learning, but what the pervasive needs of students are. You choose next-step strategies that address students' needs before proceeding to the next investigation. The notebooks act as an assessment tool that lets you modify your science instruction.

This process will take time, discussions with colleagues, revisiting different sections of this chapter, and critical scrutiny of students' work before both you and your students are using notebooks to their full potential.

### ► NOTE

For more on derivative products, see the Science-Centered Language Development chapter.



## Benefits to Students

- Documentation
- Reference document
- Cognitive engagement

## NOTEBOOK BENEFITS

Engaging in active science is one part experience and two parts making sense of the experience. Science notebooks help students with the sense-making part. Science notebooks assist with documentation and cognitive engagement. For teachers, notebooks are tools for gaining insight into students' thinking. Notebooks inform and refine instructional practice.

### Benefits to Students

**Documentation.** Science provides an authentic experience for students to develop their documentation skills. In the primary classroom, getting students to use a notebook will introduce the powerful skills of information organization. Students document their experiences, data, and thinking during each investigation. They create simple tables, graphs, charts, drawings, and labeled illustrations as standard means for representing and displaying data. At first, students will look at their science notebooks as little more than a random collection of words and pictures. Each notebook page represents an isolated activity. As students become more accomplished at keeping notebooks, their documentation will become better organized and efficient. In time and with some guidance, students will adopt a deeper understanding of their collections as integrated records of their learning.

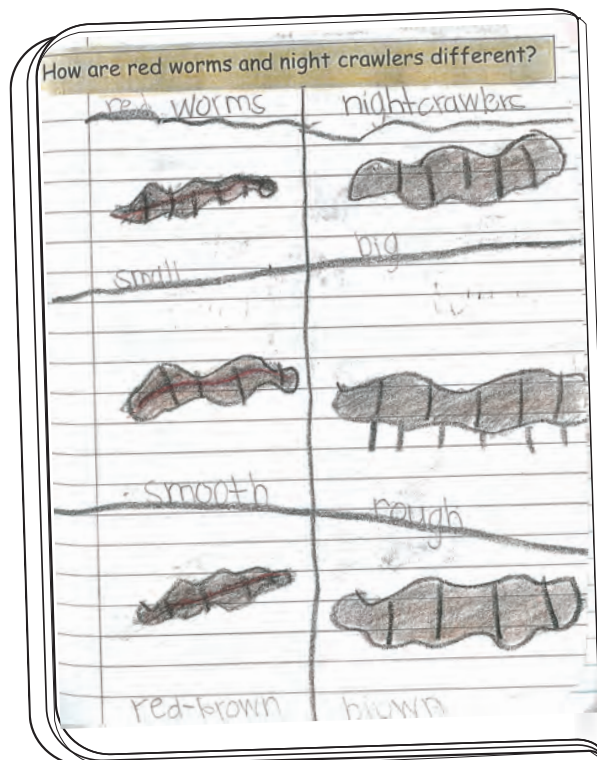

Kindergarten entry from the Animals Two by Two Module

**Reference document.** When data are displayed in functional ways, students can think about the data more effectively. Even with young students, a well-kept notebook is a useful reference document. When students have forgotten a fact about an insect or a plant that they learned earlier in their studies, they can look it up. Learning to trust a personal record of previous discoveries and knowledge structures is important.

A complete and accurate record allows students to reconstruct the sequence of learning events to “relive” the experience. Discussions about science among students; students and teachers; or students, teachers, and families have more meaning when they are supported by authentic documentation in students’ notebooks.

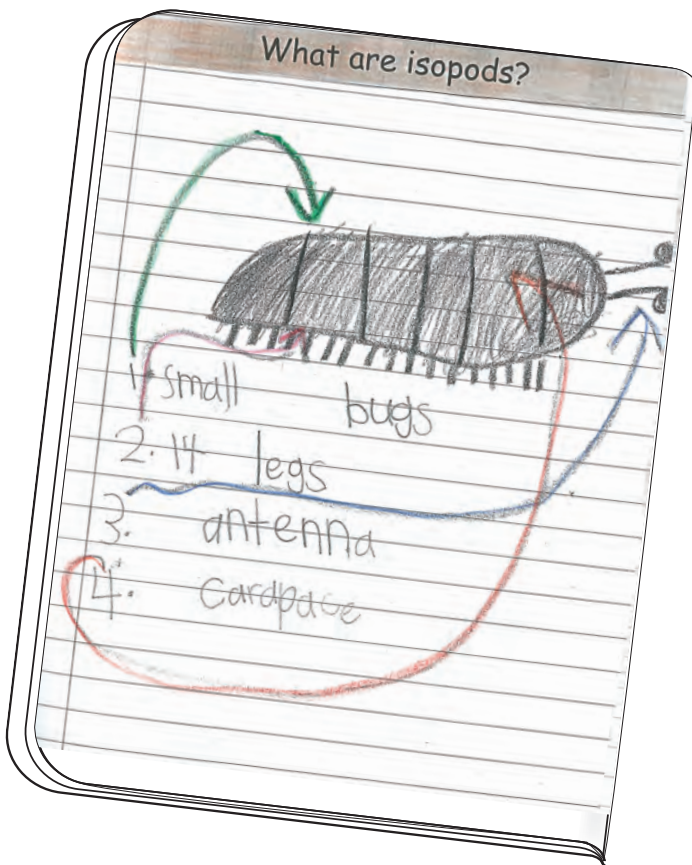

Labeled drawing from the Animals Two by Two Module

# Science Notebooks in Grades K–2

**Cognitive engagement.** Once data are recorded and organized in an efficient manner in science notebooks, students can think about the data to draw conclusions about the way the world works. Their data, based on their experiences and observations, are the raw materials that students use to forge concepts and relationships.

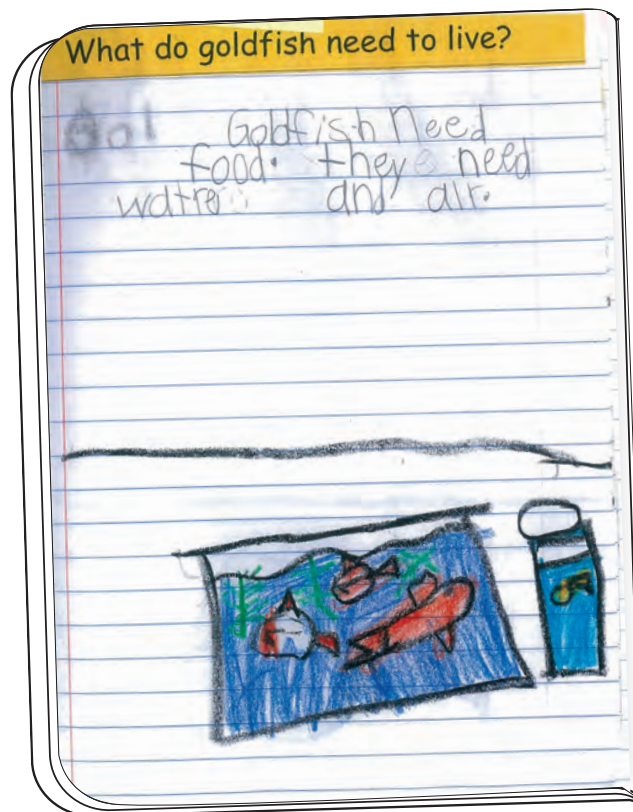

Responding to a focus question from the Animals Two by Two Module with a drawing and words



## Benefits to Teachers

In FOSS, the unit of instruction is the module—a sequence of conceptually related learning experiences that leads to a set of learning outcomes. A science notebook helps you think about and communicate the conceptual structure of the module you are teaching.

**Assessment.** From the assessment point of view, a science notebook is a collection of student-generated artifacts that exhibit learning. You can assess student skills, such as using drawings to record data, while students are working with materials. At other times, you collect the notebooks and review them in greater detail. The displays of data and analytical work, such as responses to focus questions, provide a measure of the quality and quantity of student learning. The notebook itself should not be graded. However, the notebook can be considered as one component of a student’s overall performance in science.

**Medium for feedback.** The science notebook is an excellent medium for providing feedback to individual students regarding their work. Some students may be able to read a teacher comment written on a self-stick note, think about the issue, and respond. Other students may need oral feedback individually or in a small-group situation. This feedback might include additional modeling to help students make more accurate drawings, revisiting some important vocabulary, or introducing strategies to help students better communicate their thinking.

**Focus for professional discussions.** The science notebook acts as a focal point for discussion about students’ learning at several levels. It can be reviewed and discussed during parent conferences. Science notebooks can be the focus of three-way discussions among students, teachers, and principals to ensure that all members of the school science community agree about what kinds of student work are valued and what level of performance to expect. Science notebooks shared among teachers in a study group or other professional-development environment can serve as a reflective tool that informs teachers of students’ ability to demonstrate recording techniques, individual styles, various levels of good-quality work, and so on. Just as students can learn notebook strategies from one another, teachers can learn notebook skills from one another.

## Benefits to Teachers

- *Assessment*
- *Medium for feedback*
- *Focus for professional discussions*
- *Refinement of practice*



A teacher provides feedback to a student.

# Science Notebooks in Grades K–2

**Refinement of practice.** As teachers, we are constantly looking for ways to improve instructional practices to increase students' understanding. Your use of the notebook should change over time. In the beginning, the focus will be on the notebook itself—what it looks like, what goes in it. As you become more comfortable with the notebook, the attention shifts to what students are learning. When this happens, you begin to consider how much scaffolding to provide to different students, how to use evidence of learning to differentiate instruction, and how to modify instruction to refine students' understanding.

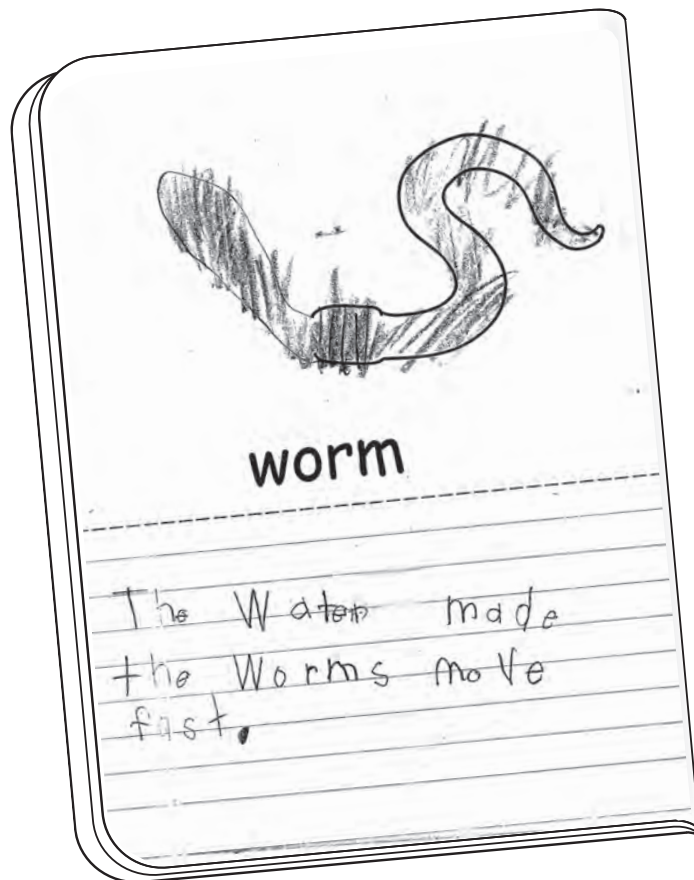

Kindergarten entry from the Animals Two by Two Module

## GETTING STARTED

Starting in kindergarten, students are expected to make detailed, thoughtful records of their science inquiries. While this may seem like a lofty goal, with some patience and thoughtful support, both teachers and students can learn how to use science notebooks effectively.

A major goal for using notebooks is to establish habits that will enable students to collect data and make sense of them. Use of the notebook must be flexible enough to allow students room to grow and supportive enough for students to be successful from the start. The format should be simple and the information meaningful to students. The notebook includes student drawings, simple writing in the form of individual words and short phrases, and a variety of visual and tactile artifacts. When students thumb through their notebooks, they are reminded of the objects and organisms they observed and their interactions with them.

### Notebook Format

Delta Education sells bound science notebooks that include printed notebook sheets specific for each module. These consumable, preprinted notebooks provide an efficient, supportive approach to early-childhood notebook keeping.

The *Teacher Resources* component of the FOSS *Teacher Toolkit* includes duplication masters for the same notebook sheets that are bound into the consumable notebooks. You can use these sheets to prepare an analogous notebook or to design a customized version.

In an autonomous approach, students create their entire science notebooks from blank pages in bound composition books. Students can glue or tape the provided notebook sheets into their notebooks, as well as create their own notebook entries. This level of notebook use will not be realized quickly and will require modeling by the teacher to provide enough structure to make the notebook useful. It will likely require systematic development by an entire teaching staff over several years.

You might choose to have a separate notebook for each module or one notebook for the entire year. (See the sidebar for the advantages of each.) Students will need about 30 pages (60 sides) for a typical module.

#### Advantages of One Notebook per Module:

- *Easy to replace if lost*
- *Lower cost*
- *Fewer pages*

#### Advantages of One Notebook per Year:

- *Easy to refer to prior activities*
- *Easy to see growth over time*

## Organization of Notebooks

Two organizational components of the notebook should be planned right from the outset for primary students—page numbering and documentation. Two additional organizational components—a table of contents and an index—might be included only in the class notebook (detailed in the Supporting Students section) or in student notebooks toward the end of second grade. Not all organizational structures need to be present in individual student notebooks in the primary grades.

**Page numbering.** Each page should have a number. These can be applied to the pages, front to back, and referenced in the table of contents as the notebook progresses, or small blocks of pages can be prenumbered (pages 1–5 initially, pages 6–10 later, and so on) at appropriate times in the module.

A parent volunteer could number the pages. If students number them, monitor their work to make sure they don't skip pages or misnumber them.

**Date, title, and other conditions.** Each time students make a new entry, they should record certain information. At the very minimum, they should record the date and a title. More complete documentation might include the time; day of the week; team members; and if appropriate, weather conditions. When introducing a new condition to students, such as recording the names of team members, it is important to discuss why students are recording the information so that they understand the relevancy.

Some classes start each new entry at the top of the next available page. Others simply leave a modest space and enter the information right before the new entry.

**Table of contents.** If students keep a table of contents in their own notebooks, they should reserve the first two pages of the notebook for it. You will need to remind students to add to it systematically as you proceed through the module. The table of contents can be based on the names of the investigations in the module, the specific activities undertaken, the concepts learned, or some other schema that makes sense to everyone.

You might provide students with a preprinted table of contents without page numbers. As students work through each investigation, they record the relevant page numbers in their table of contents. If students are making their own table of contents, they should keep it fairly simple.

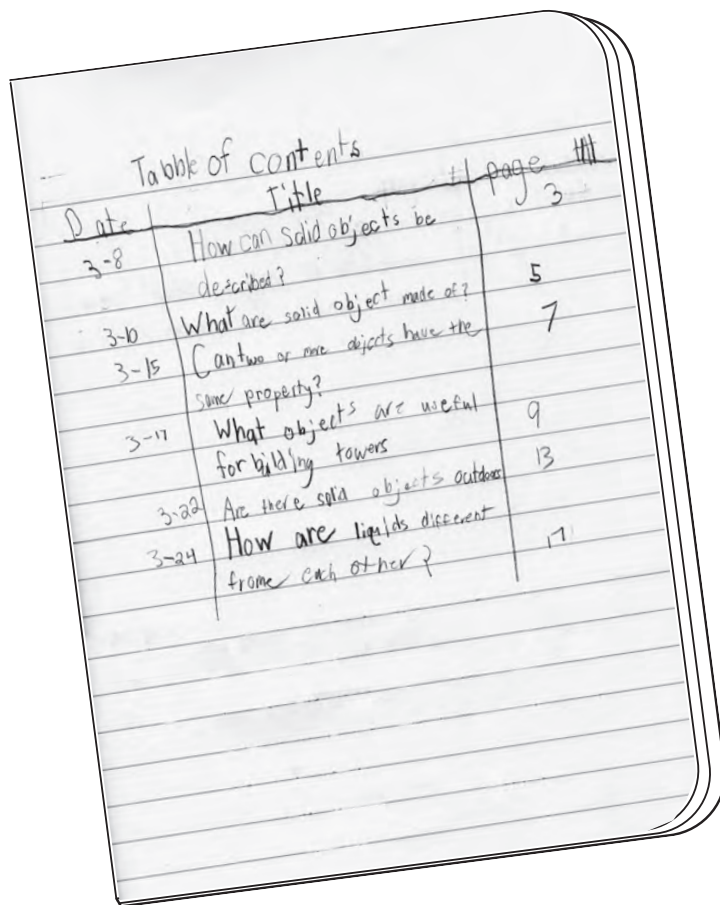

Date	Title	Page #
3-8	How can solid objects be described?	3
3-10	What are solid objects made of?	5
3-15	Can two or more objects have the same property?	7
3-17	What objects are useful for building towers?	9
3-22	Are there solid objects outdoors?	13
3-24	How are liquids different from each other?	17

A table of contents for the Solids and Liquids Module

# Science Notebooks in Grades K–2

**Index.** Scientific academic language is important. FOSS strives to have students use precise, accurate vocabulary at all times in their writing and conversations. Key words can be displayed using a pocket chart, word wall, or written on index cards kept in boxes at each table. Another support to assist with acquisition of the scientific vocabulary is to introduce an index in the class notebook. It is not usually possible to enter the words in alphabetical order, since they will be acquired as the module advances. Instead, assign a block of letters to each of several index pages at the back of the class notebook (A–E, F–K, etc.); you or students can enter key words. Students write the new vocabulary word or phrase in the appropriate square and tag it with the number of the page on which the word is defined in the notebook.

Including an index in the class notebook is a long-term time investment and can be overwhelming for the beginning notebook user. It may be better to forgo the index and use just a word wall to work with vocabulary initially.

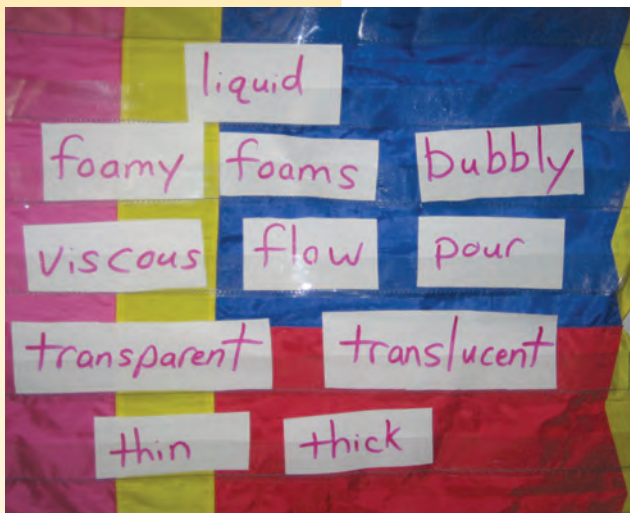

Pocket charts can be used to introduce vocabulary for students to include in their notebooks.

## Notebook Entries

As students engage in scientific exploration, they will make entries in their notebooks. They might use a prepared notebook sheet or a more free-form entry. Students frequently respond to a focus question with a drawing or a simple written entry. Kindergartners may write single words; first and second graders will write simple observations and summary ideas, using the new vocabulary in their entries. These notebook entries allow early-childhood students to relive and describe their science experiences as they turn the pages in their notebooks.

Typically, the rules of grammar and spelling are relaxed when making notebook entries so as not to inhibit the flow of creative expression. Encourage students to use many means of recording and communicating besides writing, including charts, graphs, drawings, color codes, numbers, and images attached to the notebook pages. By exploring many options for making notebook entries, each student will find his or her most efficient, expressive way to capture and organize information for later retrieval.

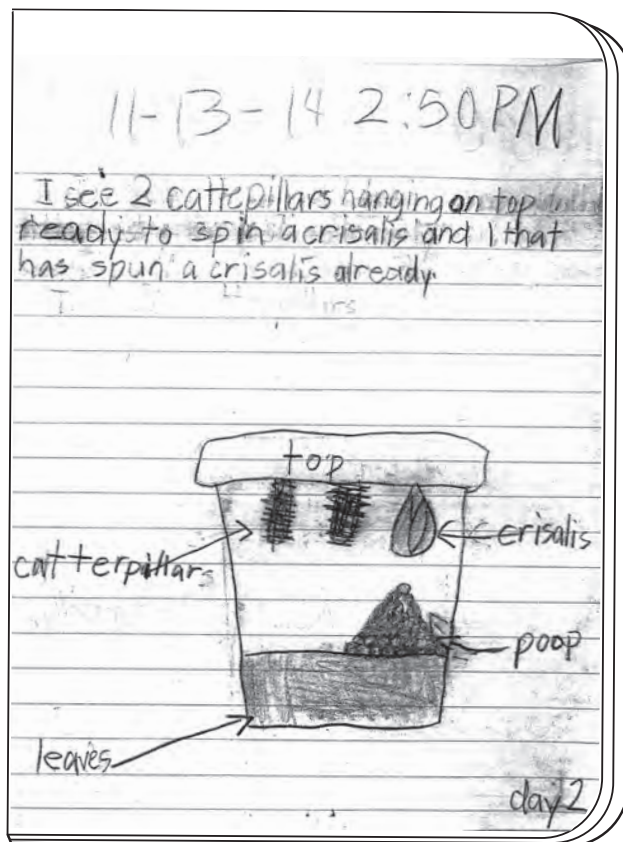

A notebook entry from the Insects and Plants Module

## TEACHING NOTE

*Use of the class notebook should be thoughtfully timed. Doing a class-notebook entry at the end of an activity is helpful to teach the components of a notebook, yet allows you to see what students do on their own. If you want to model a specific notebook strategy, use the class notebook during the activity.*

## Supporting Students

Elementary classrooms contain students with a range of abilities, which is important to take into account when thinking about strategies for implementing science notebooks. Students need to have successful early experiences with notebooks. This requires planning. For younger students, a blank notebook may be intimidating, and they will look to you for guidance. FOSS teachers have had success using different supports and scaffolds to help transform the blank notebook into a valuable reference tool.

**Class notebook.** You can create a class notebook to document scientific explorations as a way to model the various notebook components. Use a chart-paper tablet so that the pages can be flipped back and forth, and make it accessible at all times as a student reference. Students can emulate the class notebook in their own personal notebooks. Initially, individual notebooks will look quite similar to the class notebook. It is not the intent that students' notebooks be identical to the class notebook.

**Scaffolds.** Supports and scaffolds differ in one way. Supports are always available for students to access, such as allowing students access to a class notebook. Scaffolds are available just when the student needs them and will vary from student to student and from investigation to investigation. Scaffolds are meant to provide structure to a notebook entry and allow students to insert their observations into that structure. As the year progresses, the scaffolds change to allow for more student initiative. Scaffolds include

- **Sentence starters** or **drawing starters** provide a beginning point for a notebook entry.
- **Frames** provide more support but leave specific gaps for students to complete. Here's an example: "We planted \_\_\_\_\_ seeds and used \_\_\_\_\_ to water them."
- The suggested **notebook sheets** can guide students to record observations and data. The notebook sheets also guide thinking.



**Think-alouds.** Think-alouds help explain the decision-making process practiced by a savvy notebook user. They verbalize the thoughts used to create a particular notebook entry. For example, if students have recorded observations about one type of rock and are going to observe a second type, you might say,

*I am going to observe another kind of rock. I'm going to look back to see how I recorded rock information before. I see that I made a large, detailed drawing. I described the texture, size, and color of the rock, too. So now I think I will make a drawing of the new rock. I'm going to record the texture, size, and color, too.*

*Now I know that one way I can get ideas for what to write in my notebook is to look back at observations I wrote before.*

**Providing time to record.** When young students are engaged in active science, their efforts are focused on the materials, not the notebook. Students need this time to explore, and many will not open their notebooks and record observations, even with prompting. Students need separate time to record observations that fully document their discoveries. Some teachers have found it easier to leave the materials on the table and have students bring their notebooks to a common writing area. Then the teacher revisits the focus question or task and provides a few minutes for students to record in their notebooks.

**Dictation.** Students could dictate specific information to an adult. The adult writes the information in the notebook for the student. Or the adult could write the sentence, using a highlighter, and students could trace the words, using a pencil.

## Ownership

A student's science notebook can be personal or public. If the notebook is personal, the student decides how accessible his or her work is to other students. If ownership falls at the opposite extreme, everything is public, and anyone can look at the contents of anyone else's notebook at any time. In practice, most classroom cultures establish a middle ground in which a student's notebook is substantially personal, but the teacher claims free access to the student's work and can request that students share notebooks with one another and with the whole class from time to time.

# Science Notebooks in Grades K–2

## Notebook Components

- *Planning the investigation*
- *Data acquisition and organization*
- *Making sense of data*
- *Next-step strategies*

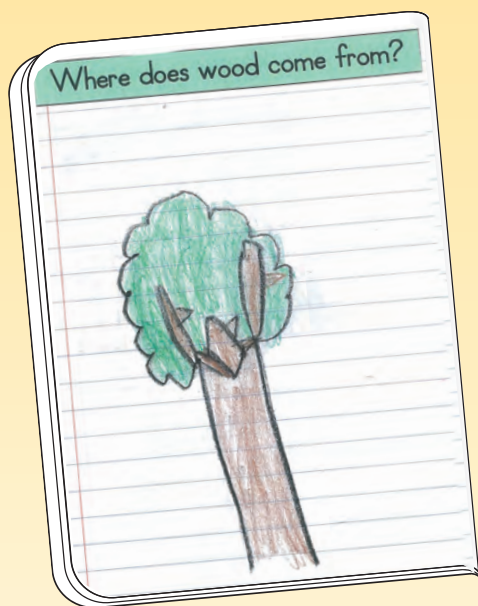

Notebook entry with focus question from the Materials in Our World Module

## TEACHING NOTE

*Student-developed plans appear infrequently in grades K–2. Asking students to record plans for every investigation is not recommended.*

## NOTEBOOK COMPONENTS

A few components give the science notebook conceptual shape and direction. These components don't prescribe a step-by-step procedure for how to prepare the notebook, but they do provide some overall guidance.

The general arc of an investigation starts with a question or challenge, and then proceeds with an activity, data acquisition, sense making, and next steps. The science notebook should record important observations and thoughts along the way. It may be useful to keep these four components in mind as you systematically guide students through their notebook entries.

### Planning the Investigation

Typically at the start of a new activity, the first notebook entry is a focus question, which students glue or transcribe into their notebooks. The focus question determines the kinds of data to be collected and the procedures that will yield those data. Depending on the timing and their previous experiences, students may be asked to record a prediction related to the focus question.

**Focus question.** Each part of each investigation starts with a focus question or challenge. The focus question establishes the direction and conceptual challenge for the activity. Write or project it on the board or on the chart for students to transcribe into their notebooks, or give them photocopied strips of the focus question to tape or glue into their notebooks. The focus-question strips are distributed as needed. Some teachers give students adhesive-backed labels with the focus questions printed on them.

### 3. How can you sink wood?

Write the focus question on the chart, and have students read it together.

➤ *How can you sink wood?*

**Plans and procedures.** Students may plan their investigation. The planning may be detailed or informal, depending on the requirement of the investigation. These plans take time to develop and additional time to document in the notebook. A brief class discussion of the procedure may lead to a sentence or two recorded in the class notebook. This will be sufficient for many of the investigations.

**Predictions.** Depending on the content and the focus question, students may be able to make a prediction. When they make predictions, they are attempting to relate prior experiences to the question posed. Providing students with a frame can help them explain the rationale behind their predictions. A frame to help with stating a prediction is “I think that \_\_\_\_\_ because \_\_\_\_\_.”

## Data Acquisition and Organization

Data are the bits of information (observations) from which scientists construct ideas about the structure and behaviors of the natural world. Because observation is the starting point for answering the focus question, data records should be

- clearly related to the focus question;
- accurate and precise;
- organized for efficient reference.

Data handling can have two phases: data acquisition and data display. Data acquisition is making observations and recording data. The data record can be composed of words, phrases, numbers, and/or drawings. Data display is reorganizing the data in a logical way to facilitate thinking. The display can take the form of narratives, drawings, artifacts, tables, graphs, images, or other graphic organizers. Early in a student’s experience with notebooks, the record may be disorganized and incomplete, and the display will need guidance. Students will need support to determine what form of recording to use in various situations and how best to display the data for analysis.

**Narratives.** The most intuitive approach to recording data for most students is narrative—using words, sentence fragments, and numbers in a more or less sequential manner. As students make a new observation, they record it right after the previous entry, followed by the next observation, and so on. Some observations, such as the changes observed in a mealworm, are appropriately recorded in narrative form.

Sentence frames provide a way for students to record their data. If students are nonwriters, they can dictate their observations, and you can write their observations in their notebooks, using a highlighter. Students can then trace the highlighted words.

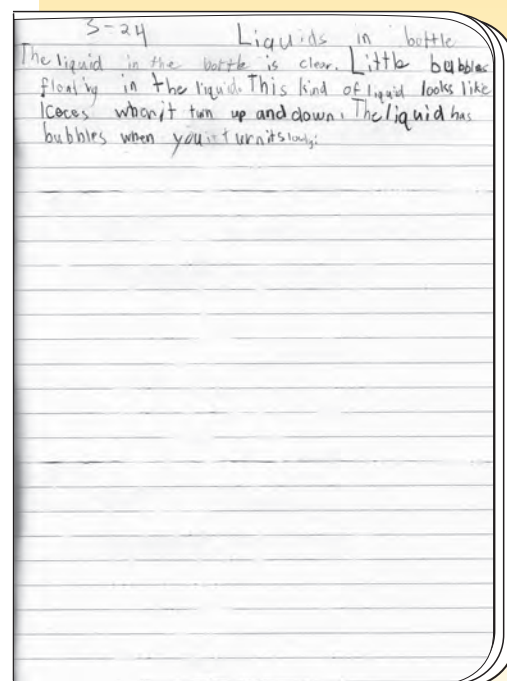

A narrative observation from the Solids and Liquids Module

# Science Notebooks in Grades K–2

**Drawings.** When students observe organisms or systems, a labeled illustration is a very efficient way to record data. A picture is worth a thousand words, and a labeled picture is even more useful.

Some young students may initially prefer drawing their observations, while others may struggle to do so. When students make drawings, it can be helpful to suggest an acronym for making useful drawings. Accurate, big, colorful, and detailed (ABCD) drawings can capture structures of an organism, a balanced object, or an observation of a liquid. Think-alouds can also help students gain insight about not only what to draw but also when a drawing is useful.

It is not unusual for students to embellish their drawings by adding features such as smiles to flowers and living organisms. While this may be appropriate for creative expression, scientific illustrations should not be anthropomorphized. Give students feedback about making authentic observations.

**Artifacts.** Occasionally, the results of an investigation produce three-dimensional products that students can tape or glue directly into their science notebooks. Rubbings, disassembled fabrics, sand, minerals, seeds, and so on can become a permanent part of the record of learning.

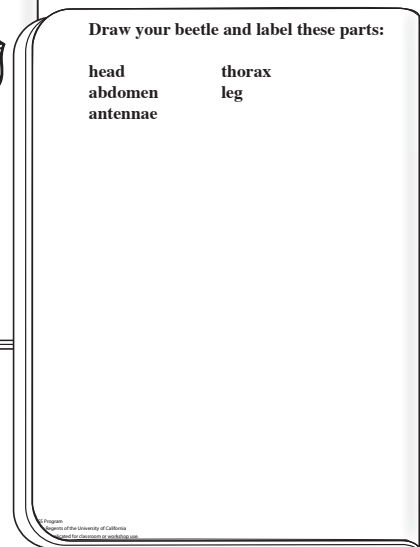
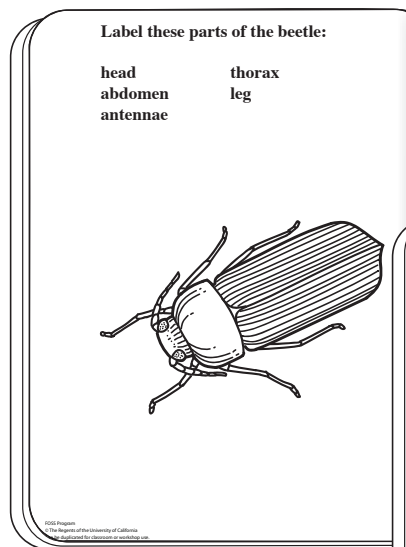
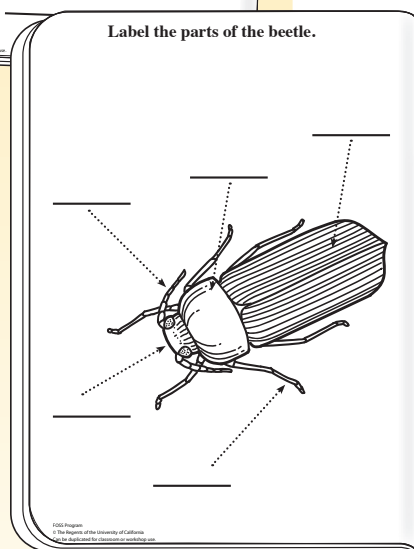
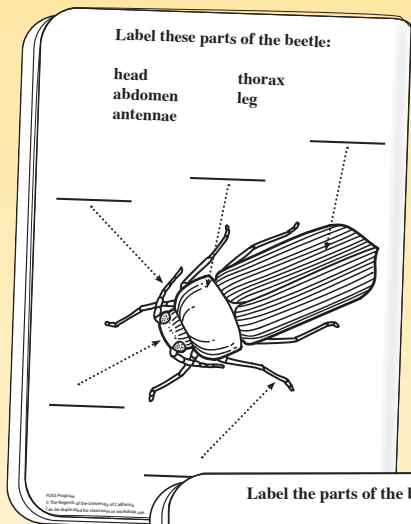

An example of different drawing scaffolds for the parts of a beetle. Different scaffolds can provide different levels of support for students. It is important to note that not all students need the same level of support.

**Tables.** When students make similar observations about a series of objects, such as properties of solid objects, a table with columns is an efficient recording method. The two-dimensional table makes it easy to compare the properties of all the objects under investigation.

Often, the preprinted notebook sheet provides a blank table. Students can quickly enter information on the notebook sheet. As students take on more independence in their notebooks, discussions about the column headings or the purpose of the tables shift the focus from filling in the table to the purpose the table serves.

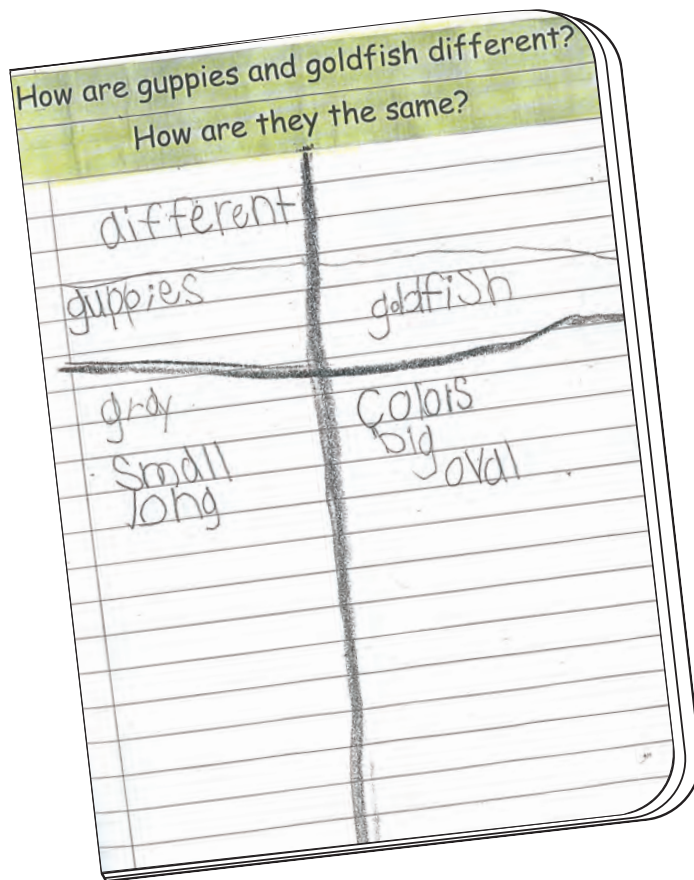

How are guppies and goldfish different?	
How are they the same?	
guppies	goldfish
gray	Colors
small	big
long	oval

A simple table from the Animals Two by Two Module

**Graphs and graphics.** Reorganizing data into a logical, easy-to-use graphic is an important phase of data analysis. Bar graphs allow easy comparison. Additional graphic tools, such as concept maps and life cycles, help students make connections between data accrued during investigations.

For kindergarten students, you will need to model and scaffold graphs and graphics when students are ready. Visuals displayed in students' notebooks should also appear in a larger format on a whiteboard, projected display, or in the class notebook. You can use this larger display to connect organized data to the content students are learning.

**Images.** Digital photos of plants, rocks, and the results of investigations can be great additions to the science notebook.

## Making Sense of Data

The third component of an investigation involves analyzing the data to learn something about the natural world. Establishing the habit of thinking about the data collected and using them to help us answer a question is important.

Most of the sense making in the primary classroom takes place during whole-group discussions when students share and discuss the observations they made while investigating. Questions are asked to help students interpret and analyze data in order to build conceptual understanding. Encourage students to use new vocabulary when they are sharing and making sense of their data. These words should be accessible to all students in the class notebook and displayed in the room. When students have limited written language skills, this oral discussion is important. This sharing is essential and is described in detail in the *Investigations Guide*. After sharing observations, the class revisits the focus question. Students flip back in their notebooks and use their data to discuss their answers to the question. You scaffold the discussion, and use appropriate language-development strategies.

### 8. Ask questions to guide discussion

Ask questions to guide students' observations and discussion.

- ▶ *Were you able to sink the wood by attaching paper clips?*
- ▶ *How many paper clips did you use to sink the wood?*
- ▶ *Let's compare the two samples. Does it take the same number of paper clips to sink both kinds of wood?*
- ▶ *Does it make a difference where you put the paper clips on the wood? All on one side? Evenly distributed around all sides?*

After the sense-making discussion, students might review relevant vocabulary. Then they answer the focus question in their notebooks. In the beginning, you might model this writing in a class notebook, or students might work in small groups to write a collaborative response. Students could also make a drawing as a response to a focus question. As students become more proficient writers, they will begin to record their own written responses to the focus question.

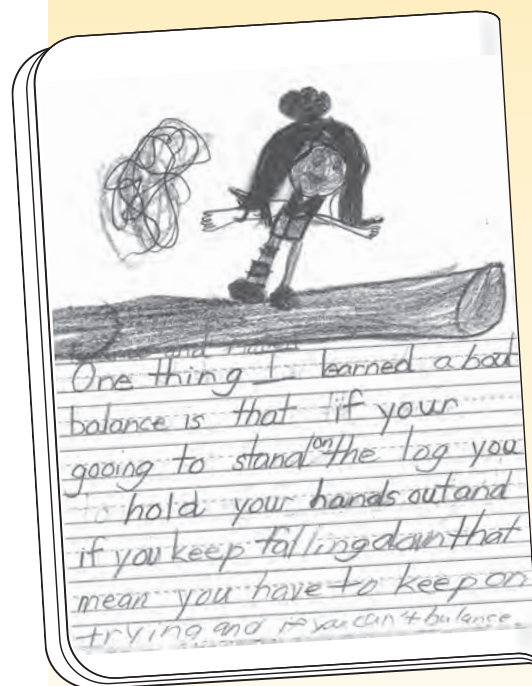

A sense-making entry from the Balance and Motion Module

# Science Notebooks in Grades K–2

Making sense of data is an opportunity for students to grapple with scientific concepts. The expectation is that all students will engage in this component. In many instances, using assistive structures, such as frames and prompts to guide the development of a coherent and complete response to the focus question, will help establish this expectation.

**Thinking with evidence.** In the primary classroom, students are expected to explain their thinking and provide some supporting evidence. While their explanations and evidence may be relatively simple, they will provide you with evidence of student understanding. A student might conclude that objects that have a round surface will roll because a ball and a can both rolled and they have round surfaces. The evidence should refer to specific observations, measurements, and so on.

For example, an investigation in the **Animals Two by Two Module** poses the focus question

► *What is the difference between red worms and night crawlers?*

Students observe and record, using the class notebook as a model. You create a Venn diagram, with input from students during discussion that compares the two types of worms. Students hear the focus question again, and they discuss their thinking in their groups. You write this frame in the class notebook

*One difference between a red worm and a night crawler is \_\_\_\_\_ .  
I know this because \_\_\_\_\_ .*

All students get a preprinted frame to glue into their notebooks and answer independently. Be careful not to display conclusions or other sense-making entries in a class notebook before students make their own entries. Otherwise, assessment of student thinking becomes difficult, as a student may copy the class-notebook response with little understanding of the meaning.

## TEACHING NOTE

*If students respond verbally, it is important to record those responses in the science notebook to establish that notebooks are a place to document understandings.*

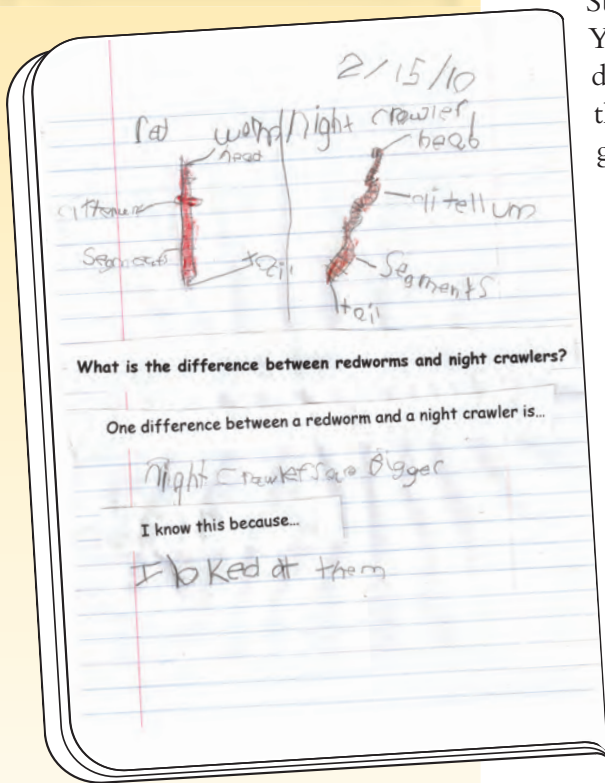

An answer to a focus question from the **Animals Two by Two Module**



**Frames and prompts.** Providing frames helps students organize their thinking. The frame provides a communication structure that allows students to focus on thinking about the science involved. This could be identifying the difference between two worms, students’ thoughts about which types of objects roll, or how people can change the shape of wood. The frame does not do the thinking for students, but allows them to respond to the focus question in a clear, coherent manner.

- *One difference between the red worm and the night crawler is \_\_\_\_\_.*
- *I noticed that all the things that rolled \_\_\_\_\_.*
- *I know this because \_\_\_\_\_.*

**I wonder.** Does the investigation connect to a student’s personal interests? Or does the outcome suggest a question or pique a student’s curiosity? Providing time for students to write “I wonder” statements or questions supports the idea that the pursuit of scientific knowledge does not end with the day’s investigation. The notebook is an excellent place to capture students’ musings and for students to record thoughts that might otherwise be lost.

**Wrap-up/warm-up.** At the end of each investigation part or at the beginning of the next part, students will engage in a wrap-up or warm-up. This is another opportunity for students to revisit the content of the investigation. As they discuss their responses to the focus question with a partner, students may choose to edit their responses or add fresh information. This should be encouraged.

### TEACHING NOTE



*Frames can be used to model how to write a good response. Some students may be able to revisit and modify previously used frames to answer additional questions.*

### 13. Share notebook entries

Conclude Part 4 or start Part 5 by having students share notebook entries. Ask students to open their science notebooks to the most recent entry. Read the focus question together as a class.

➤ *How can you sink wood?*

Ask students to pair up with a partner to

- share their answers to the focus question;
- explain their drawings.

## TEACHING NOTE

*Students' learning can be assessed only at the level in which it was done. If students worked in groups to answer the focus question, it is difficult to assess individual understanding. Similarly, providing a frame to guide a student response provides evidence on what students can do at a supported level, not at an independent level.*

## TEACHING NOTE

*These next-step strategies should be kept simple for primary students. The key idea is that students can revise their responses after gaining more information.*

## Next-Step Strategies

In each investigation, the *Investigations Guide* indicates an assessment opportunity and what to look for when examining students' work. The purpose of looking at students' work at this juncture is for formative, or embedded, assessment, *not* for grading. Look for patterns in students' understanding by collecting and sorting the notebooks. If the patterns indicate that students need additional help with communication or with content, you might want to select a next-step strategy before going on to the next part. This process of looking at students' work is described in more detail in the Assessment chapter.

A next-step strategy is an instructional tool designed to help students clarify their thinking and usually takes place before the start of the next investigation part. A strategy is selected based on students' needs. It may be that a student needs to communicate his or her thinking more efficiently or accurately or to use scientific vocabulary. A student may need to think about the concept in a different way. Because many young students are not able to articulate their thinking well in writing, it can be difficult to discern the area of need.

What follows is a collection of next-step strategies that teachers have used successfully with groups of students to address areas of need. These strategies are flexible enough to use in different groupings and can be modified to meet your students' needs.

**Teacher feedback.** Students’ writing often exposes weaknesses in students’ understanding—or so it appears. It is important to check whether the flaw results from poor understanding of the science or from imprecise communication. When students are able to read your comments, you can use self-stick notes to provide constructive feedback or dig deeper into students’ thinking. The note might pose a question designed to move a student’s thinking forward or to clarify an explanation. The student acts independently on the question.

When students have not developed the reading skills necessary to act independently on written feedback, read the question or prompt to the student. Language skills are supported when students have the opportunity to connect the written feedback to what you read to them.

The most effective forms of feedback relate to the content of the work. Here are a couple of examples.

- *Label your drawing to show the parts of the plant.*
- *Tell me why you think you were able to balance the triangle and the arch.*

Nonspecific feedback (such as stars, smiley faces, and “good job!”) and ambiguous critiques, (such as “try again,” “put more thought into this,” and “not enough,”) are less effective. Feedback that guides students to think about the content of their work and gives suggestions for how to improve are productive instructional strategies. Here are some examples of useful generic feedback.

- *Use the science words in your answer.*
- *Can you tell me why you think that?*
- *Why do you think that happened?*

Students return to their notebooks and read or listen to the feedback at the start of the next investigation. They can discuss this feedback with a partner during the warm-up time and refine their responses. You could model this refinement as a think-aloud or by using the class notebook. Monitor students to ensure that they are acting on the feedback provided.

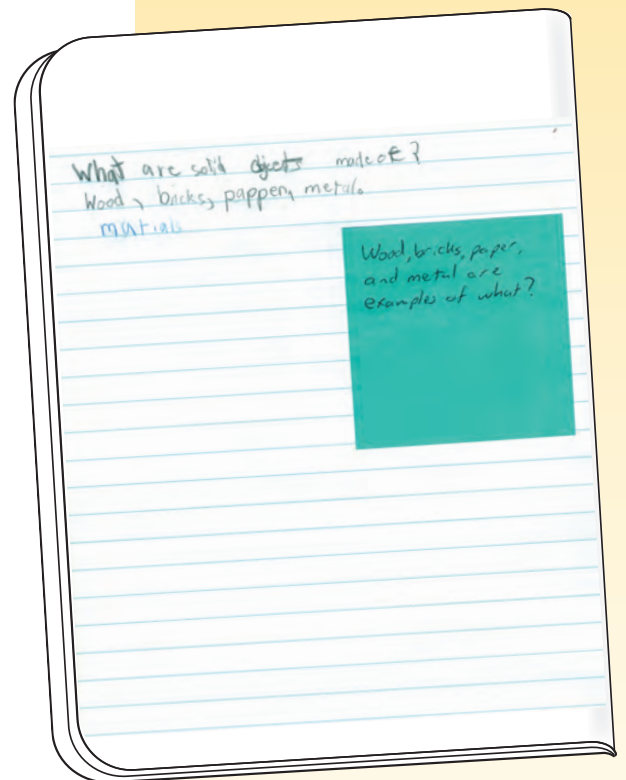

Students can respond to feedback by using a different color to show their new understanding.

# Science Notebooks in Grades K–2

**Review and critique anonymous student work.** Presenting work from other students can be a valuable learning tool for refining and improving the content and literacy of responses. Depending upon the culture of the class, you might present actual or simulated student work from a focus question or responses that reflect a common misconception, error, or exemplary work. Present it to the class in a common gathering area, such as on a rug, or display it electronically while students are at their seats. Present one simple response, such as a labeled drawing. Students then work in a group to discuss the merits and recommend improvements to the student response. In this process, students discuss what information is needed for a quality response. After critiquing other students' responses, students look at their own responses and refine their thinking. Students could also use a different-color crayon or pencil to make changes to their own responses.

**Key points.** Pose the focus question to the class, and, through discussion, elicit the key ideas or points that would completely answer the question. List only key words or brief phrases on the board. If you have already recorded the key points in the class notebook, revisit that

list as well. Once the class has agreed on the key points, students review their own responses, looking for the key points. You can guide this by calling out each key point on the list, and asking students to put a finger on it in their notebooks. If students need to add the key point, they can add it in another color.

**Mini-lessons.** Sometimes the data from sorting notebook entries reveal that students need some information repeated or specific guidance on a skill. A mini-lesson is a brief interaction with a group of students that addresses a specific area of need. You might have a group of students observe a mealworm more closely in order to count the number of segments, or give students a writing prompt and work with them to explain their thinking more clearly.



## WRITING OUTDOORS

Every time you go outdoors with students, you will have a slightly different experience. Naturally, the activity or task will be different, but other variables may change as well. The temperature, cloud cover, precipitation, moisture on the ground; other activities unexpectedly happening outside; students' comfort levels related to learning outdoors; and time of the school year are all aspects that could affect the activity and will certainly determine how you incorporate the use of notebooks. The following techniques are tried-and-true ways to help students learn how to write outdoors and to give them all the supplies they need to support their writing.

### Create “Desks”

Students need a firm writing surface. Students who write in composition notebooks with firm covers can simply fold them open to the pages they are writing on, rest them in the crook of their nonwriting arms, and hold them steady with their nonwriting hands—they can stand, sit, kneel, or lean against a wall to write. At the beginning of the school year, take a minute to model how to do this.

Many students feel most comfortable sitting down to write. Curbs, steps, wooden stumps or logs, rocks, and grass are places to sit while writing. Select a writing location that suits your students' comfort levels. Some students will not be comfortable sitting on the grass or ground at first. They will need to sit on something such as a curb, boulder, or wooden stump at the start of the year, but will eventually feel more comfortable with all aspects of the outdoor setting as the year moves along.

If students are using individual notebook sheets or notebooks with flimsy covers, you will likely want to buy or make clipboards. If you do not have clipboards, use a box cutter to cut cardboard to the proper size. Clamp a binder clip at the top to make a lightweight yet sturdy clipboard. If it gets ruined, no tears will be shed. If you're in the market for new clipboards, get the kind that are stackable and do not have a bulky clip. Ideally, all the clipboards will fit in one bag for portability and easy distribution.

If using a notebook sheet, simply put the sheet on the clipboard before going outdoors, and have students glue the sheet into their notebooks when you are back in the classroom. An elastic band around the bottom of the clipboard, or around a stiffer composition notebook, will help keep the paper from flapping around and becoming too weathered.

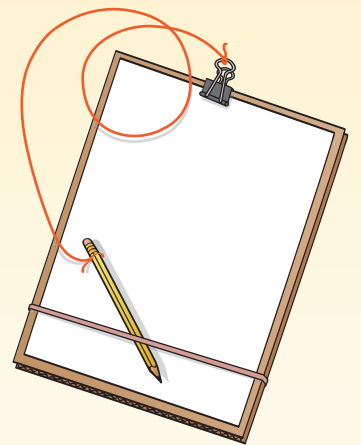

## Bring Writing Tools Outdoors

Almost always, students will set up their notebooks indoors so that they know what is expected of them outdoors. If students will be recording data, they will carry their pencils and notebooks or clipboards outdoors and hold on to them the entire time. Make sure students understand how and what to record.

You can bring chart paper outdoors. Roll up a blank piece of chart paper, grab some blue painter's tape, and stick the piece of paper to the school wall. You'll need to tape all four corners. Or set up a chart inside and clip it to a chain-link fence with binder clips or clothespins when you go outdoors.

Take along extra pencils, as many pencil points will break. Some teachers find it helpful to tie pencils onto clipboards. Pencils should be tucked between the clip and the notebook sheet so that students don't poke themselves or, more likely, accidentally break the pencil points.

Another option is to prepare a cloth bag containing small pencil sharpeners, extra pencils, and other science tools, such as vials, hand lenses, and rulers.

## Decide When to Write Outdoors

In general, notebook entries will be more detailed and more insightful if students can stay outdoors where the scientific exploration occurred. Sometimes, you will want to complete notebook entries indoors. If you are teaching the module early in the year when students are building up the routines for using the schoolyard, or if the weather is not ideal (a little chilly, raining, too hot, too windy), then you may want students to make notebook entries after returning to the classroom. If students are totally focused and in the moment, they can stay outdoors while they answer the focus question. If other students are outdoors playing, you may need to bring the class indoors to complete the written work. Only you will be able to determine what is best at the time.



## CLOSING THOUGHTS

Engaging primary students in active science with notebooks provides a rich experience. Doing this successfully requires thoughtful interactions among students, materials, and natural phenomena. Initially, adding notebooks to your science teaching will require you to focus students' attention on how to set up the notebook, what types of entries students should make, and when students should be using their notebooks. You will establish conventions about where to record the date and title, where to keep notebooks, how to glue notebook sheets into notebooks, and when to record observations and thinking.

Once you are past these perfunctory issues, you can shift your focus to the amount of scaffolding to provide to students or to encouraging students to create their own notebook entries. During this time, you and your students are developing skills to improve the quality of notebook entries. These skills may include asking better questions to focus students' attention on a specific part of an organism or using color to enhance a drawing. Students begin to make entries with less prompting. They give more thought to supporting their responses to the focus question. When asked to make a derivative product, students thumb through their notebooks to find the needed information. The notebook becomes a tool for students to help recall their learning.

As students begin to document their thinking about focus questions and other queries, you may begin to wonder, "Should I be doing something with their notebooks?" This is when your focus shifts from the notebook as just something students use during science learning to the notebook as an assessment tool. Once everyone is comfortable recording the focus question and collecting data, you can take the next step of collecting notebooks and reading students' responses as a measure of not just how individual students are learning, but what the pervasive needs of students are. You choose next-step strategies that address students' needs before proceeding to the next investigation. The notebooks act as an assessment tool that lets you modify your science instruction.

This process will take time, discussions with colleagues, revisiting different sections of this chapter, and critical scrutiny of students' work before both you and your students are using notebooks to their full potential.

### ► NOTE

For more on derivative products, see the Science-Centered Language Development chapter.